

Article

Fixed Points of Set Valued Mappings in Terms of Start Point on a Metric Space Endowed with a Directed Graph

Murchana Neog [†] and Pradip Debnath ^{*,†}

Department of Mathematics, North Eastern Regional Institute of Science and Technology, Nirjuli 791109, Arunachal Pradesh, India; murchananeog@gmail.com

* Correspondence: debnath.pradip@yahoo.com; Tel.: +91-857-515-8469

† These authors contributed equally to this work.

Academic Editor: Pasquale Vetro

Received: 28 June 2016; Accepted: 14 April 2017; Published: 19 April 2017

Abstract: In the present article, we introduce the new concept of start point in a directed graph and provide the characterizations required for a directed graph to have a start point. We also define the notion of a self path set valued map and establish its relation with start point in the setting of a metric space endowed with a directed graph. Further, some fixed point theorems for set valued maps have been proven in this context. A version of the Knaster–Tarski theorem has also been established using our results.

Keywords: start point; fixed point; set valued mapping; metric space with a graph

1. Introduction

At present, fixed point theory is an immensely active area of research due to its applications in multiple fields. It addresses the results which state that, under certain conditions, a self map on a set admits a fixed point. Among all the results in fixed point theory, the “Banach Contraction Principle” in metric fixed point theory is the most celebrated one due to its simplicity and ease of application in major areas of mathematics. Following the Banach Contraction Principle, Boyd and Wong [1] investigated the fixed point results in nonlinear contraction mappings. Subsequently, many authors extended and generalized this fixed point theorem in different directions.

Study of fixed point results in partially ordered sets has been a very well motivated research area because of its ease of compatibility in modelling various problems and in finding new convergence schemes. The first attempt in this direction was carried out by Ran and Reurings [2] who combined the Banach contraction principle and the Knaster–Tarski fixed point theorem. Ran and Reurings considered a class of mappings $f : X \rightarrow X$, with (X, d) as a complete metric space and a partial order \leq . The mappings they considered were continuous and monotone with respect to the partial order \leq . Those mappings also satisfy a Banach contraction inequality for every pair $(x, y) \in X \times X$ such that $x \leq y$. When for some $x_0 \in X$, the inequality $x_0 \leq f(x_0)$ is satisfied, they proved that the Picard sequence $\{f^n(x_0)\}$ would converge to a fixed point of f . Ran and Reurings also combined this interesting result with the Schauder fixed point theorem and applied it to obtain some existence and uniqueness results to nonlinear matrix equations.

Neito and Rodríguez-López ([3,4]) extended the results of Ran and Reurings to the functions which were not necessarily continuous. The authors also applied their results to obtain a theorem on the existence of a unique solution for periodic boundary problems relative to ordinary differential equations.

Some very important works in this direction that deserve attention are [5–18].

Nadler [19] and Assad and Kirk [20] established some very important fixed point results for set valued and multivalued contraction mappings. Meanwhile, Espinola and Kirk [21] combined the concepts of fixed point theory and graph theory to prove some interesting fixed point theorems in R -trees. In 2008, Jachymski [22] introduced an interesting idea of using the language of graph theory in the study of fixed point results. He was interested in establishing results that would eventually generalize the existing results and also in applying the results to the theory of linear operators. So, he studied the class of generalized Banach contractions on a metric space with a directed graph. The advantage of using graph theoretical concepts was that it helped him to describe the results in a unified way and also weaken some conditions significantly. Such works were further extended by Bojor [23,24] in a significant way.

Very recently, some fixed point results on subgraphs of directed graphs were established by Aleomraninejad, Rezapour and Shahzad [6,25]. They showed that the Caristi fixed point theorem and a version of the Knaster–Tarski fixed point theorem are special cases of their results. Inspired by their work, in the present paper, we prove some fixed point theorems in the case of set valued mappings in the setting of a metric space with a graph by defining a new notion called start point of a directed graph.

Let (X, d) be a complete metric space and $CB(X)$ be the class of all nonempty closed and bounded subsets of X . For $A, B \in CB(X)$, let:

$$D(A, B) = \max\{\sup_{b \in B} d(b, A), \sup_{a \in A} d(a, B)\},$$

where $d(a, B) = \inf_{b \in B} d(a, b)$. Then $(CB(X), D)$ is a metric space and D is said to be a Hausdorff metric induced by d .

Let (X, d) be a metric space and $\Delta = \{(x, x) : x \in X\}$ denote the diagonal of the Cartesian product $X \times X$. Consider a directed graph G such that the set of its vertices coincides with X (i.e., $V(G) = X$) and the set of its edges $E(G)$ is such that $\Delta \subseteq E(G)$, i.e., G contains all the loops. We assume G has no parallel edges and thus we identify G with the pair $(V(G), E(G))$.

If $x, y \in V(G)$, then a path in G from x to y is a sequence $\{x_i\}_{i=0}^n$ of vertices such that $x_0 = x$, $x_n = y$ and $(x_{i-1}, x_i) \in E(G)$ for $i = 1, 2, \dots, n$.

In this article, we assume that a path may be finite or infinite and a cycle may be considered as a finite path. Also, we assume that G has no isolated vertex.

2. Main Results

Now we are ready to discuss our main results. The following definitions will be useful in this context.

Definition 1. Let $CB(X)$ be the class of all nonempty closed and bounded subsets of X . For each $x \in V(G)$, the notation $[Tx]_G$ denotes a class of nonempty closed and bounded subsets of G such that $[Tx]_G = \{A \in CB(X) : \text{there exists a path from } u \text{ to } x \text{ for some } u \in A\}$.

Definition 2. We say that the set valued map $T : X \rightarrow CB(X)$ is a self-path map, whenever, for each $x \in V(G)$, there is a path from u to x for some $u \in Tx$, we denote this by $Tx \in [Tx]_G$.

When $x \neq y$, by the notation $Tx \in [Ty]_G$ we mean that there is a path from x to Ty for some $u \in Ty$.

Also, we define $[y]_{G^l}$ as $[y]_{G^l} = \{x \in G : \text{there exists a path from } y \text{ to } x\}$.

Furthermore, the point $x \in V(G)$ is said to be a fixed point of the set valued map $T : X \rightarrow CB(X)$ if $x \in Tx$.

The next example motivates the study of multivalued mappings by showing that control problems may be translated in terms of multivalued maps, and hence, study of their fixed points could provide new solution schemes to such problems.

Example 1. Suppose that the following control problem is to be solved:

$$\begin{aligned} x'(t) &= f(t, x(t), u(t)), \\ \text{and } x(0) &= x_0, \end{aligned}$$

which is controlled by parameters $u(t)$ (called the controls), where $f : [0, a] \times \mathbb{R}^n \times \mathbb{R}^m \rightarrow \mathbb{R}^n$.

To solve the above problem, we define a multivalued map $F : [0, a] \times \mathbb{R}^n \rightarrow \mathbb{R}^n$ as follows:

$$F(t, x) = \{f(t, x, u)\}_{u \in U}.$$

Then solutions of the above problem are solutions of the following differential inclusions:

$$\begin{aligned} x'(t) &\in F(t, x(t)), \\ \text{and } x(0) &= x_0. \end{aligned}$$

Definition 3. Let G' be a subgraph of the directed graph G . We say that $c \in V(G)$ is a lower bound for G' whenever $g' \in [c]_{G'}$ for all $g' \in V(G')$. Also, we say that $d \in V(G)$ is an infimum of G' whenever $d \in [c]_{G'}$ for all lower bounds c .

Definition 4. Let G be a directed graph and $u \in V(G)$. We say that u is a start point whenever there is no $x \in V(G)$ such that $x \neq u$ and $(x, u) \in E(G)$.

Definition 5. Let H be a subgraph of the directed graph G . A vertex $s \in V(H)$ is said to be a start point of H if there is no $x \in V(H)$ such that $x \neq s$ and $(x, s) \in E(G)$.

Definition 6. Let (X, d) be a metric space and $\phi : X \rightarrow (-\infty, \infty)$ a map. Suppose that G is the directed graph defined by $V(G) = X$ and $E(G) = \{(x, y) : d(x, y) \leq \phi(x) - \phi(y)\}$. We say that ϕ is upper semicontinuous whenever $\phi(x_n) \leq \phi(x)$ for all sequences $\{x_n\}$ in X such that $\{x_n\}$ converges to x .

Our first result uses the concept of a minimal path. If Y denotes the set of all paths in a directed graph G , then (Y, \subseteq) is a partially ordered set. Also, since it is trivially true that every partially ordered set has a minimal element, we can conclude that G has a minimal path.

Theorem 1. Let G be a directed graph such that every path in G has a lower bound within itself. Then, there exists a path in G , considered as a subgraph of G , which has a start point or a cycle.

Proof. We assume that G has no cycle. Let M be a minimal path in G and $l \in V(M)$ be a lower bound of M . If l is not a start point, then there exists $x \in V(M)$ such that $x \neq l$ and $(x, l) \in E(G)$. Then, $M \setminus \{x\}$ is a path in G and $M \setminus \{x\} \subset M$. This contradicts the fact that M is a minimal path. Hence, l must be a start point of M . \square

Below, we give an example to verify Theorem 1.

Example 2. Let $X = \{x_1, x_2, x_3, \dots\}$ and G be a directed graph with vertices $V(G) = X$. Suppose H is a subgraph of G with vertices $H = \{x_1, x_2, x_3, x_4, x_5, x_6, x_7\}$ and the edges $E(H) = \{(x_1, x_3), (x_1, x_4), (x_1, x_5), (x_2, x_6), (x_3, x_2), (x_4, x_7), (x_5, x_6), (x_7, x_6)\}$ (Figure 1).

Then, it is easy to see that H has no cycle and every path in H has a lower bound within itself. Here, $x_1 \rightarrow x_5 \rightarrow x_6$ is a minimal path, which has a start point x_1 .

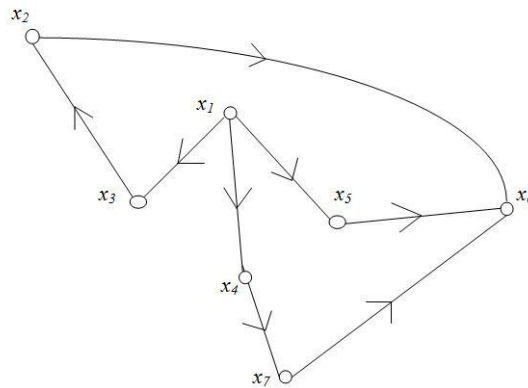

Figure 1. Existence of a path with a start point.

Theorem 2. Let G be a directed graph. Then, G has a start point if and only if each self path map on G has a fixed point.

Proof. Let G be a graph with a start point s and T be a self path map on G . We claim that s is a fixed point of T . Since $Ts \in [Ts]_G$, there is a path (finite or infinite) from $u \in Ts$ to s . However, since s is a start point, this is not possible for any s unless $u = s$. Thus, we must have $s \in Ts$, i.e., s is a fixed point of T .

Again, suppose G is a directed graph and each self path map on G has a fixed point. If possible, assume that G has no start point. Then, for each $x \in V(G)$, there exists $y \in V(G)$ such that $y \neq x$ and $(y, x) \in E(G)$. Now, considering every such pair $(y, x) \in E(G)$, we can define a map $T : G \rightarrow CB(G)$ such that for each $x \in V(G)$, $Tx = \{y\}$. It is easy to see that T is a self path map because $Tx = \{y\} \in [Tx]_G$, for all $x \in V(G)$, but T has no fixed point as $x \notin Tx$ for any $x \in V(G)$. This contradicts our hypothesis and thus G has a start point. \square

Our next example shows that, indeed, if a directed graph has no start point, then a self-path map may be defined which has no fixed point.

Example 3. Let G be a directed graph with vertices $V(G) = \{a, b, c, d, e\}$ and the edges $E(G) = \{(e, d), (d, c), (c, b)\} \cup \{(a, e), (a, d), (c, a), (b, a)\}$ (Figure 2).

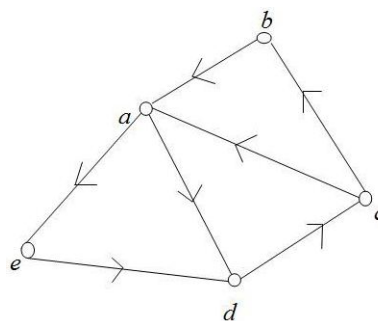

Figure 2. A directed graph with no start point.

Define the map $T : V(G) \rightarrow CB(X)$ such that $Ta = \{b\}, Tb = \{c\}, Tc = \{d\}, Td = \{e\}, Te = \{a\}$. Then, it is easy to see that T is a self path map but G has no fixed point and no start point either.

Theorem 3. Let G be a directed graph such that every path in G has an infimum within itself and let $T : V(G) \rightarrow CB(X)$ be a self-path map. Also, let $G' = \{x \in V(G) : Tx \in [Tx]_G\}$ and G' has no cycle. Then, T has a fixed point in G' .

Proof. Let B be a path in G' and $b \in V(G)$ be its infimum (greatest lower bound). Therefore, from the definition of self path map, we have $Tb \in [Tb]_G$, which implies that $b \in V(G')$. Also, G' is a subgraph of G . Now, using Theorem 1, G' has a start point. Again, since T may be considered as a self-path map on G' , using Theorem 2 we can conclude that T has a fixed point in G' . \square

Below, we show that using Theorem 3, a version of the Knaster–Tarski fixed point theorem can be established.

Theorem 4. Let (X, \leq) be a partially ordered set such that each chain in X has an infimum within itself and let $T : V(G) \rightarrow CB(X)$ be a monotone self-path map. Then, T has a fixed point.

Proof. We define the graph G as $V(G) = X$ and $E(G) = \{(x, y) : x \leq y \text{ and } x \neq y\}$. Then, $Tx \in [Ty]_G$ for all $x \in [y]_{G'}$. Let $G' = \{x \in V(G) : Tx \in [Tx]_G\}$. Then, G' is a subgraph of G and it has no cycle. Thus, by using Theorem 3, we can conclude that T has a fixed point in G' . \square

Lemma 1. Let X be a complete metric space and let $\phi : X \rightarrow (-\infty, \infty)$ be a map bounded from above. Suppose that G is the directed graph defined by $V(G) = X$ and $E(G) = \{(x, y) : d(x, y) \leq \phi(x) - \phi(y)\}$. If ϕ is upper semicontinuous, then G has a start point.

Proof. First, we prove that G has no cycle. If G has a cycle, then there exists a finite path $\{\lambda_i\}_{i=1}^n$ in G such that $\lambda_1 = \lambda_n$ (for, in a cycle, initial and terminal vertices are same).

Now, $d(\lambda_i, \lambda_1) \leq \phi(\lambda_i) - \phi(\lambda_1)$, and also, $d(\lambda_i, \lambda_1) \leq \phi(\lambda_1) - \phi(\lambda_i) = -[\phi(\lambda_i) - \phi(\lambda_1)]$. However, this is possible only when $\phi(\lambda_i) = \phi(\lambda_1)$, i.e., $d(\lambda_i, \lambda_1) \leq 0$. This implies that $\lambda_i = \lambda_1$ for all $i \geq 2$, which is a contradiction. Thus, G cannot have any cycle.

Next, we show that each path in G has a lower bound. Let $\{x_\lambda\}_{\lambda \in \Lambda}$ be a path in G . Then, $\{\phi(x_\lambda)\}_{\lambda \in \Lambda}$ is an increasing net of real numbers. As ϕ is bounded from above, we can obtain a decreasing sequence $\{\lambda_n\}_{n \geq 1}$ such that $\lim_{n \rightarrow \infty} \phi(x_{\lambda_n}) = \sup_{\lambda \in \Lambda} \phi(x_\lambda)$.

Now:

$$\begin{aligned} d(x_{\lambda_n}, x_{\lambda_m}) &\leq d(x_{\lambda_n}, x) + d(x, x_{\lambda_m}), \text{ for } n, m \geq 1 \\ &= \phi(x_{\lambda_n}) - \phi(x) + \phi(x) - \phi(x_{\lambda_m}) \\ &= \phi(x_{\lambda_n}) - \phi(x_{\lambda_m}) \\ \Rightarrow \lim_{n, m \rightarrow \infty} d(x_{\lambda_n}, x_{\lambda_m}) &\leq \lim_{n \rightarrow \infty} \phi(x_{\lambda_n}) - \lim_{m \rightarrow \infty} \phi(x_{\lambda_m}) \\ &= \sup \phi(x_\lambda) - \sup \phi(x_\lambda) \\ &= 0. \end{aligned}$$

Therefore, we have that $\{x_{\lambda_n}\}_{n \geq 1}$ is a Cauchy sequence. Since X is complete, $\{x_{\lambda_n}\}$ must converge to some $x \in X$. As ϕ is upper semicontinuous, we now have $\phi(x_{\lambda_n}) \leq \phi(x) \Rightarrow 0 \leq \phi(x) - \phi(x_{\lambda_n})$ i.e., $d(x, x_{\lambda_n}) \leq \phi(x) - \phi(x_{\lambda_n})$.

Thus, $x_{\lambda_n} \in [x]_{G'}$ for all $n \geq 1$. So, x is a lower bound for $\{x_{\lambda_n}\}_{n \geq 1}$. Now, we show that x is a lower bound for $\{x_\lambda\}_{\lambda \in \Lambda}$. If there exists $\mu \in \Lambda$ such that $x_{\lambda_n} \in [x_\mu]_{G'}$, for all $n \geq 1$, then $\phi(x_{\lambda_n}) \leq \phi(x_\mu)$ for all $n \geq 1$ which implies that $\phi(x_\mu) = \sup_{\lambda \in \Lambda} \phi(x_\lambda)$. Since $d(x_{\lambda_n}, x_\mu) \leq \phi(x_{\lambda_n}) - \phi(x_\mu)$, from the definition of upper semicontinuous map, we have $x_{\lambda_n} \rightarrow x_\mu$. This implies that $x_\mu = x$ (for $x_{\lambda_n} \rightarrow x$). Hence, $\phi(x) = \sup_{\lambda \in \Lambda} \phi(x_\lambda)$. We claim that $x_\lambda \in [x]_{G'}$. In fact, if there is $\lambda \in \Lambda$ such that $x \in [x_\lambda]_{G'}$ then $d(x_\lambda, x) \leq \phi(x_\lambda) - \phi(x) \leq \phi(x_\lambda) - \phi(x_\lambda) = 0$, and so, $x_\lambda = x$. Since $\{x_\lambda\}_{\lambda \in \Lambda}$ is a path in G , if the previous case is not true, then for each $\lambda \in \Lambda$, there exists $n \geq 1$ such that $x_\lambda \in [x_{\lambda_n}]_{G'}$.

Again, we have $x_{\lambda_n} \in [x]_{G'}$. This implies that $x_\lambda \in [x]_{G'}$. Thus, x is a lower bound for $\{x_\lambda\}_{\lambda \in \Lambda}$. Now, using Theorem 1, we can say that G has a start point. \square

Theorem 5. Let (X, d) be a complete metric space, $\phi : X \rightarrow (-\infty, \infty)$ a map bounded from above and upper semicontinuous and $T : X \rightarrow CB(X)$ a self path map satisfying the condition $d(u, x) \leq \phi(u) - \phi(x)$, for all $x \in X$ and $u \in Tx$. Then, T has a fixed point.

Proof. Suppose that G is the directed graph via the vertices $V(G) = X$ and the edges $E(G) = \{(x, y) : d(x, y) \leq \phi(x) - \phi(y)\}$. Using Lemma 1, we can conclude that G has a start point. Again, using Theorem 2, it is routine to check that T has a fixed point. \square

The following example verifies Theorem 5.

Example 4. Let $X = \{1, 2, 3, 4\} = V(G)$ and $E(G) = \{(2, 1), (3, 2), (4, 1), (4, 3), (4, 4)\}$ (Figure 3).

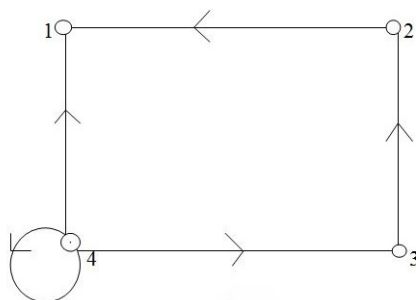

Figure 3. A graph defined via the elements of a metric space and edges satisfying a metric condition.

Consider the closed and bounded subsets of X as $\{4\}$ and $\{3, 4\}$. Define $T : X \rightarrow CB(X)$ as follows:

$$Tx = \begin{cases} \{4\}, & x \in \{3, 4\} \\ \{3, 4\}, & x \notin \{3, 4\}. \end{cases}$$

It is easy to verify that T is a self path map. Let $V(G)$ be endowed with metric $d : X \times X \rightarrow (0, \infty)$ by $d(x, y) = |x - y|$, for all $x, y \in X$. Define $\phi : X \rightarrow (-\infty, \infty)$ by $\phi(t) = \frac{5t}{2}$. Then, the conditions of Theorem 5 are satisfied. Thus, T has a fixed point 4.

3. Conclusions

In this article, the new concept of start point in a directed graph has been introduced and some fixed point theorems for set valued mappings have been established with the help of start point in the setting of a metric space endowed with a directed graph. A version of the Knaster–Tarski fixed point theorem has also been established. Our results unify and extend some existing results in literature. The results discussed in this paper are mainly concerned with the existence of fixed points. The study of the uniqueness of fixed points in the current context would be an interesting topic for future study.

Author Contributions: Pradip Debnath and Murchana Neog conceived and designed the definitions and theorems; Pradip Debnath and Murchana Neog proved the theorems; Murchana Neog typed the paper.

Conflicts of Interest: The authors declare no conflict of interest.

References

1. Boyd, D.W.; Wong, J.S. On nonlinear contractions. *Proc. Am. Math. Soc.* **1969**, *20*, 458–464.
2. Ran, A.C.M.; Reurings, M.C.B. A fixed point theorem in partially ordered sets and some applications to matrix equations. *Proc. Am. Math. Soc.* **2004**, *132*, 1435–1443.
3. Nieto, J.J.; Rodríguez-López, R. Contractive mapping theorems in partially ordered sets and applications to ordinary differential equations. *Order* **2005**, *22*, 223–239.

4. Nieto, J.J.; Rodríguez-López, R. Existence and uniqueness of fixed point in partially ordered sets and applications to ordinary differential equations. *Acta Math. Sin. Engl. Ser.* **2007**, *23*, 2205–2212.
5. Agarwal, R.P.; O'Regan, D. Fixed point theory for generalized contractions on spaces with two metrics. *J. Math. Anal. Appl.* **2000**, *248*, 402–414.
6. Aleomraninejad, S.M.A.; Rezapour, S.; Shahzad, N. Some fixed point results on a metric space with a graph. *Topol. Appl.* **2012**, *159*, 659–663.
7. Alfuraidan, M.R. On monotone pointwise contractions in Banach spaces with graph. *Fixed Point Theory Appl.* **2015**, doi:10.1186/s13663-015-0390-6.
8. Alfuraidan, M.R. Remarks on monotone multivalued mappings on a metric space with graph. *J. Inequal. Appl.* **2015**, doi:10.1186/s13660-015-0712-6.
9. Alfuraidan, M.R.; Khamsi, M.A. Fixed points of monotone nonexpansive mappings on a hyperbolic metric space with a graph. *Fixed Point Theory Appl.* **2015**, doi:10.1186/s13663-015-0294-5.
10. Beg, I.; Butt, A.R.; Radojević, S. The contraction principle for set valued mappings on a metric space with a graph. *Comput. Math. Appl.* **2010**, *60*, 1214–1219.
11. Debnath, P. Fixed points of contractive set valued mappings with set valued domains on a metric space with graph. *TWMS J. Appl. Eng. Math.* **2014**, *4*, 169–174.
12. Eshi, D.; Das, P.K.; Debnath, P. Coupled coincidence and coupled common fixed point theorems on a metric space with a graph. *Fixed Point Theory Appl.* **2016**, doi: 10.1186/s13663-016-0530-7.
13. Gwozdz-Lukawska, G.; Jachymski, J. IFS on a metric space with a graph structure and extensions of the Kelisky-Rivlin theorem. *J. Math. Anal. Appl.* **2009**, *356*, 453–463.
14. Lakshmikantham, V.; Ćirić, L. Coupled fixed point theorems for nonlinear contractions in partially ordered metric spaces. *Nonlinear Anal. Theory Methods Appl.* **2009**, *70*, 4341–4349.
15. Nieto, J.J.; Pouso, R.L.; Rodríguez-López, R. Fixed point theorems in ordered abstract spaces. *Proc. Am. Math. Soc.* **2007**, *135*, 2505–2517.
16. Petruşel, A.; Rus, I.A. Fixed point theorems in ordered L-spaces. *Proc. Am. Math. Soc.* **2006**, *134*, 411–418.
17. Sintunavarat, W.; Kumam, P.; Cho, Y.J. Coupled fixed point theorems for nonlinear contractions without mixed monotone property. *Fixed Point Theory Appl.* **2012**, *170*, 1–16.
18. Sintunavarat, W.; Radenović, S.; Golubović, Z.; Kumam, P. Coupled fixed point theorems for F-invariant set. *Appl. Math. Inf. Sci.* **2013**, *7*, 247–255.
19. Nadler, S.B. Multi-valued contraction mappings. *Pac. J. Math.* **1969**, *30*, 475–488.
20. Assad, N.A.; Kirk, W.A. Fixed point theorems for set-valued mappings of contractive type. *Pac. J. Math.* **1972**, *43*, 553–561.
21. Espinola, R.; Kirk, W.A. Fixed point theorems in R-trees with applications to graph theory. *Topol. Appl.* **2006**, *153*, 1046–1055.
22. Jachymski, J. The contraction principle for mappings on a metric space with a graph. *Proc. Am. Math. Soc.* **2008**, *136*, 1359–1373.
23. Bojor, F. Fixed point theorems for Reich type contractions on metric spaces with a graph. *Nonlinear Anal. Theory Methods Appl.* **2012**, *75*, 3895–3901.
24. Bojor, F. Fixed points of Kannan mappings in metric spaces endowed with a graph. *Analele Universitatii "Ovidius" Constanta Seria Matematica* **2012**, *20*, 31–40.
25. Aleomraninejad, S.M.A.; Rezapour, S.; Shahzad, N. Fixed point results on subgraphs of directed graphs. *Math. Sci.* **2013**, *7*, 41.

