

Article

Perceived Accuracy of Electronic Performance Appraisal Systems: The Case of a Non-for-Profit Organization from an Emerging Economy

Zia Ullah ^{1,*} , Naveed Ahmad ² , Miklas Scholz ^{3,4,5,*} , Bilal Ahmed ⁶, Ilyas Ahmad ⁷ and Muhammad Usman ⁷¹ Department of Business Administration, Lahore Leads University, Lahore 54000, Pakistan² Faculty of Management Studies, University of Central Punjab, Lahore 54000, Pakistan; naveeddgk2010@gmail.com³ Department of Building and Environmental Technology, Division of Water Resources Engineering, Faculty of Engineering, Lund University, P.O. Box 118, 221 00 Lund, Sweden⁴ Civil Engineering Research Group, School of Science, Engineering and Environment, The University of Salford, Newton Building, Salford M5 4WT, UK⁵ Department of Town Planning, Engineering Networks and Systems, South Ural State University (National Research University), 76, Lenin Prospekt, 454080 Chelyabinsk, Russia⁶ School of Management, Zhejiang University of Technology, Hangzhou 310058, China; bilal@whu.edu.cn⁷ Department of Economics and Business Administration, Division of Arts and Social Sciences, University of Education, Lahore 54000, Pakistan; ilyas.ahmad@ue.edu.pk (I.A.); usmanzuel@yahoo.com (M.U.)

* Correspondence: chairperson.ba@leads.edu.pk (Z.U.); miklas.scholz@tvrl.lth.se (M.S.)



Citation: Ullah, Z.; Ahmad, N.; Scholz, M.; Ahmed, B.; Ahmad, I.; Usman, M. Perceived Accuracy of Electronic Performance Appraisal Systems: The Case of a Non-for-Profit Organization from an Emerging Economy. *Sustainability* **2021**, *13*, 2109. <https://doi.org/10.3390/su13042109>

Academic Editor: Mário José Baptista Franco

Received: 16 January 2021

Accepted: 12 February 2021

Published: 16 February 2021

Publisher's Note: MDPI stays neutral with regard to jurisdictional claims in published maps and institutional affiliations.



Copyright: © 2021 by the authors. Licensee MDPI, Basel, Switzerland. This article is an open access article distributed under the terms and conditions of the Creative Commons Attribution (CC BY) license (<https://creativecommons.org/licenses/by/4.0/>).

Abstract: Performance appraisal reports provide vital information for making strategic decisions. Uniting HR practices and IT is an attempt to maximize value creation. Organizations are transforming their performance management systems from traditional to web-technology based systems to enhance accuracy and objectivity. The present study is an effort to assess employees' perception of the accuracy of e-performance appraisal systems. To that effect, 500 close-ended questionnaires were administered to randomly selected employees working for a non-for-profit organization where e-performance appraisal is practiced. A total of 352 questionnaires were included for analysis and structural equation modeling was used to analyze the data. The results indicate that rater competence and the possibility to challenge performance appraisals judged as unfair or inaccurate highly influence the employees' perception of accuracy of e-performance appraisals. Furthermore, a clear communication of standards and the reaction to the last rating moderately affect the employees' perception of the accuracy of e-PA.

Keywords: e-performance appraisal; rater competence; appeal platform; PA-fairness; PA-accuracy

1. Introduction

Organizational sustainability is directly related to performance management [1]. It includes strategies and activities aimed at fulfilling the organizations and their stakeholders' needs, while also maintaining, increasing, and protecting the human and financial resources they may require in the future [2]. Technology is the way forward towards organizational and environmental sustainability. One of the biggest challenges faced by contemporary managers is sustainability, which refers to the creation of meaningful values that shape strategic decision-making, promoting the reinforcement of desirable behaviors. Furthermore, the use of technology, particularly information technology and the digitalization of organizational practices, guarantee overall efficiency and effectiveness. Introduction of computer and IT in HR practices ensures objectivity, accuracy, impartiality, and justice, providing organizations with social sustainability.

Applying electronic Human Resources Management (e-HRM) to performance management has enabled organizations to provide feedback on a more frequent basis, to enhance

employees' participation and accountability, to involve peers in the feedback process, and to enhance the social outcomes of performance feedback [3]. Real-time goal setting is often integrated into e-HRM tools with a clear linkage between individual and organizational goals [4]. An effective performance management system should also align with an organization's HR management system [5,6]. Indeed, over the past 40 years, organizations have increasingly adopted e-HRM applications (including e-performance management and e-compensation systems) for achieving administrative and strategic improvements, such as cost reduction and service improvement [7]. Fisher, et al. [8] contend that for a performance measure to be valid, it must be relevant, non-deficient, and uncontaminated.

Performance management and appraisal plays a key role in the effective management of employees, particularly for service-oriented organizations. Due to the tendency to shift from a tangible asset system to an intangible one, organizations are looking for solutions to manage and maximize the performance of their workforce. E-HRM is assumed to be a driving force behind HRM value creation. On the other hand, IT aims at enhancing the accuracy and efficiency of the employees.

Performance appraisal (PA) is an instrument for optimizing management and workforce towards achieving important organizational goals. As a result of the appraisal, the organization will increase its knowledge of its workers performance, define rewards and sanctions, and plan new goals. Employees often exhibit strong attitudes towards performance appraisal. If the appraisal triggers negative attitudes among the employees, it may hinder rather than promote positive outcomes. For instance, the results could hurt the employee's self-esteem, or the employee could fear for his job continuity or for not receiving any future salary increases. These reactions can obstruct any constructive discussion between a supervisor and their subordinates to set new goals. Still, most employees wish to be informed about their performance, especially if they have been recently hired or assigned to a new position and feel insecure about their duties and assignments.

E-HRM consists of the combination of IT and HRM [9]. Researchers have given different definitions of e-HRM over the last decades, depending on the different perspectives they followed in their HRM developments. Researchers investigating the impact of IT on HRM defined e-HRM as 'the planning, implementation, and application of information technology for both connecting and supporting at least two persons or collective actors in their collective performing HR practices [10], and recently as 'the use of computers and telecommunication instruments to gather, stock, regain, and disseminate (HR) data for management purposes' [11]. Researchers working on IT-based interventions in HRM have defined e-HRM as "the administrative support of the HR function in organizations by using internet technology" [12], an approach of implementing HRM plans, strategies, and activities in organizations through the deliberate and direct support of and/or with the use of computer-based technologies [13]. By taking both specific definitions into consideration, we can give a general definition of e-HRM as being the integration of IT into HRM for improving its outcomes. It concerns all HR related content that is communicated through IT. E-HRM aims at an efficient management of the personnel of the organization and at creating long-term reliable opportunities inside and outside the organization. Previous studies suggest that e-HRM has the potential to improve HRM service quality [14], or in other words to improve the intangible services provided by HR professionals to managers and other employees. Clients of HRM services rely on what is intangibly exchanged between HR experts and HR clientele [15]. The intangible nature of HRM forces HR professionals to display responsiveness to each customer demand. However, as customers are not rewarded for their contributing in HRM services, a big effort has to be spent on involving them in the process. For instance, a line manager can be reluctant to fill an evaluation required by the new e-HRM services and has to be convinced to feel involved [16,17]. In conclusion, e-HRM appears as a HRM channel supporting intangibility, simultaneity, and customer participation.

Current e-HRM-related literature points at a relevant improvement of HRM services after applying e-HRM in different organizations [18–21]. Particularly, researchers claim

that e-HRM provides a better service to organizations' internal customers such as managers and other employees. Evidence points at positive outcomes provided by e-HRM to HRM practices through the provision of accurate data, the simplification of processes and the increase of HRM related experience of internal customers of HRM services [22–24].

EP management is a competency-based management system targeting the evaluation of the employees on the basis of goal accomplishment and the definition of the competencies required to achieve their tasks. All the employees' goals are supported with competency ratings that will ease their achievement. The evaluations allow to assess if a particular employee owns the pertinent qualifications for fulfilling his job. If the employee lacks any of these qualifications, action can be taken by providing him/her with the necessary training for learning said qualifications. The employee's competency and ratings are placed in the core of HRM practices. Other processes such as talent searches, learning, and succession planning can leverage the data gathered by EP management [25]. However, identifying each employee's capabilities and talents for promoting their positive contribution and managing low performance is not an easy task [26]. In addition, a growing number of organizations are seeking a universal solution that can be supported globally and be applied to all nations, regions, cultures, and individuals while conveying steady messages, promoting accountability, and providing evaluation reports [27].

PA aims at addressing the drawbacks of contemporary performance management and promoting important changes to current work culture. PA activities range from formal meetings between evaluators and employees, to informal remarks made by an evaluator to an employee during the observation of his work with the purpose of evaluating his performance [28]. PA is a process intended to record the employees' performance and to identify his needs for training and development. PA provides a holistic view of the work activities, to analyze what has been accomplished within the reporting period and to set standards for the following period.

The dynamic development of modern technologies affects a number of areas of the organization functioning. One of them is Human Resources Management. Electronically Managing HR activities is relatively new in Pakistan where it is rarely found in organizations. Most organizations follow a traditional HR management system for many reasons like its cost, the employees' reluctance towards change, and because they often endure technology anxiety. On the other hand, a review of literature indicates that e-PMS has not been extensively investigated in Pakistan. For that reason, this article focuses on examining employees' perceptions of e-PA systems, to deeply understand how they work in settings with no experience with this kind of management practice. We also aim at assessing the attitude of employees towards the changes introduced to their working environment and their tasks through this kind of implementation. The introduction of e-PA has been studied in the context of a non-for-profit organization for the first time. To the best of our knowledge, no other example of the sort has been found in this regard. To this effect, data was collected through close ended personal questionnaires performed to 325 employees of a non-for-profit oncology hospital and research center. Structural equation modeling (SEM) was used to test the hypotheses.

2. Theoretical Framework

The attitude of the employees towards the PA system has been described by different theories such as the equity theory [29], the expectancy theory [30], and the feedback intervention theory [31]. According to the equity theory, the PA system generates a constructive attitude provided that employees judge the PA results as fair. The overall perception of employees illustrates a positive evaluation towards distributive, interpersonal, and procedural justice in performance appraisal. The expectancy theory states that the motivation behind a rater conducting an effective and accurate performance appraisal of an employee is dependent on the manager's expectations. A correct, fair, and timely performed PA will result in performance improvement. Expectancy theory applied to PA focuses on the present performance of an employee and on motivation to enhance his/her performance.

In this context, knowing the PA process for better examining his/her abilities for performing his/her tasks leads to a better PA outcome [32,33]. The feedback intervention theory consists of providing the employee with feedback on the gap between his expected and actual performance to motivate him/her to improve their performance.

This article focuses on the employee's perception of fairness and accuracy of e-PA processes, rather than in the involvement of the employee in the use of IT in PA. Equity Theory has been chosen as the foundation of the study because employees expect procedures to be fair, bias free, accurate, amendable, participative, and ethical. The perception of procedural justice enhances positive attitude of the employees towards the PA outcomes. Expectations, a fair evaluation, and an unbiased and competent approach of the appraiser will result in a better opinion of the employees regarding e-PA.

In order to describe the employee's perceived accuracy of e-PA we used confidence on rater, concerns over rating, seeking appeal, clarity expectations and standards, and reaction to the last rating and the supervisor as exogenous variables.

2.1. Definition of Variables

Perception of *accuracy of rating* (AR) is set as a criterion variable. Accuracy of PA is explained through six items. The construct was operationalized along the perception of exactitude of evaluation of the quality and quantity of the work performed by the employee and his job responsibility.

Clarity of expectations and standards (CES) is set as the independent variable. It is measured along eight items after factor loading. It involves clearly and timely communicating the standards against which performance is appraised. It also involves receiving instant feedback and guidance to improve performance.

Confidence over rater (COR) is a predicting variable. It is operationalized along four items after factor loading. It is concerned with the objective, impartial, and fair rating of performance. The appraisal is concerned with the quality and quantity of work rather than personality and position of the employee.

Seeking appeal (SA) is an independent variable involving the disagreement of the employee with the PA results which are judged as unfair or inaccurate. It is measured with the help of six observations. Appeal happens when an employee can disagree with the performance appraisal as he thinks it is done unfairly and inaccurately. This variable depends on the evaluation fairness and the possibility to challenge the rating.

Rater Competence (RC) is used as an endogenous variable and refers to the ability of the rater. It is dependent on rater's knowledge of the PA and his ability to manage its IT implementation. It is dependent in the qualification of the rater, the understanding of standards the requirements of the tasks and the knowhow of e-PA systems.

Reaction to last rating and rater (RLRS) is used as an independent variable which refers to a bias-free, accurate, and objective evaluation of performance related to the last period. It also refers to the fairness and abilities of the rater who performed the previous period evaluation.

2.2. Hypotheses

The goal-setting theory [34] states that clarity of expectations towards employees plays an important role in enabling them to follow standards, accept expectations show willingness about improving the aspects underlined by the evaluation. As a result, performance clarity standards lead to an increase in productivity [31,34]. In turn, the control theory [35] points out that clear communication of the performance standards reduces the gap between the actual and the expected performance standards set by the organization [36]. According to Morrison's model the employees expect the standards to reduce uncertainty in their task execution and to increase their knowledge about their tasks, resulting in a higher performance. Reduced uncertainty leads to desirable working attitudes and a higher performance. Similarly, Taylor, et al. [37] noted that the employees' clear understanding

of behavioral standards provided by the evaluation feedback will result in performance improvements. Thus, we can formulate the following hypothesis:

Hypothesis 1 (H1). *Clear communication of expectations and standards positively affect the employee's perception of the accuracy of e-performance appraisals.*

Literature about organizational justice suggests that organizational fairness may encourage the employees to accept the decisions taken after HR interventions such as PA [38]. There are three types of fairness perception: (i) distributive justice refers to the perceived fairness of an actual appraisal rating, (ii) procedural justice refers to the way fairness is perceived regarding the procedures used to determine appraisal rating and (iii) interactional justice refers to the employees' perception of the fairness of the rater's interpersonal interaction with himself during the appraisal process. According to this reasoning, we made the following hypothesis:

Hypothesis 2 (H2). *Perceived fairness and impartiality positively affect the employee's perception of the accuracy of e-performance appraisals.*

No process involving human intervention is error-free. There is always a possibility that human and technology driven errors as well as process and structural inefficiencies occur during e-PA, leading to flawed performance assessment reports [39]. Possible contingency measures include the availability of a platform where an affected or unsatisfied employee can request for a re-evaluation of his performance [40]. Beer [41] notes that the risk for an unfair assessment is reduced by the availability of manager to discuss the reports with the concerned employee, and by providing the employee with the possibility to be reevaluated if he judges the appraisal unfair. As a consequence, the following hypothesis is formulated:

Hypothesis 3 (H3). *The availability of ways to seek appeal, when employee feels that appraisal has been done unfairly or inaccurately, positively affect employee's perception of accuracy of e-performance appraisal.*

Several issues could arise in the process of performance appraisal [42]. The competencies generally lacking are knowledge, skills, expertise, experience, and positive attitude. Different research results focusing on rater errors [43], the influence of organizational context on the raters' behavior, [43] and the rating inaccuracy [44] of PAs are often difficult to accomplish within the complex and dynamic working environment [45].

Thus, the following hypothesis is developed:

Hypothesis 4 (H4). *The competence of appraiser regarding e-PA positively affects employee's perception of accuracy of e-performance appraisal.*

The employees past experience have a relevant influence on their current way of seeing the world. Their reaction to the last PA is essential for PA effectiveness [46]. The employees that have been rated critically and carefully evaluate the accuracy of PA reports on the basis of rater competence and impartiality, communication of standards, relevancy and proper use of technology, use of correct data, and presence of procedural and distributive justice [47]. A competent appraiser triggers employees' positive attitudes towards performance PA. Thus, we hypothesize that:

Hypothesis 5 (H5). *Employee's experience of last e-performance appraisal and appraiser positively affect employee's perception of accuracy of e-performance.*

3. Methodology

3.1. Research Design

The study is cross sectional, explanatory, and quantitative in nature. Survey design has been used to collect data. Data collection was performed in the Shaukat Khanam Cancer Hospital and Research Center (Pakistan). The choice of this center is justified by different reasons. Firstly, e-PAs have been carried out in the center on an annual and semiannual basis for many years and consequently, the employees are used to PAs. Secondly, it is an important organization with 2700 employees, thus offering a large sample for analysis. Furthermore, we preferred to collect all the data from a single center to ensure homogenous conditions for all the data. Finally, The Shaukat Khanam Hospital is a research center familiarized with providing the data collection.

3.2. Sample and Respondents Composition

A sample of 500 questionnaires was provided to randomly selected employees from which 325 showed an acceptable level of accuracy. Simple random sampling was followed to ensure representativeness. The questionnaires were provided with the cooperation and coordination of the HR department of the hospital. The composition of the sample consisted of 68% male and 32% female. By age group, 9% were younger than 25 years old, 43% 26–35 years old, 25% were 36–40 years old, 20% were 41–50 years old, and 3% were older than 50 years old. For years of professional experience, 40% had less than 5 years, 40% had 6–10 years, 14% had 11–15 years, and 6% had more than 15 years of experience. According to positions, 9% were managers and 91% had other positions. By qualification, 21% were college graduates 48% were bachelor's degree holders.

3.3. Measurement Instrument

The questionnaire designed for evaluating the model consisted of 6 items for measuring the Accuracy of Rating (AR), 12 items for the Clarity of Expectations and Standards (CES), 6 items for the Confidence over Rater (COR), 5 observations for the Rater Competence (RC), 9 items for the Reaction to Last Rating and Rater (RLRS) and 6 observations for the measure of the Seeking Appeal (SA). Items scoring less than 0.65 were excluded for factor analysis, [48]. Four CES items and two COR items were removed accordingly (item scores are shown in Figure 1). Reliability was established by using Cronbach's alpha: all the variables scored more than 0.70 and thus considered to be highly reliable.

The following Table 1 shows variables and the related items that measure them.

3.4. Data Analysis

Data was analyzed using inferential statistics. For this purpose, structural equation modeling (SEM) using partial least square (PLS) was used. SEM enables researchers to study the measurement component (factor model) and structural component (path model) simultaneously in one model. Thus, SEM provides a comprehensive picture of the reliability and validity of the data and cause-and-effect relationships.

Table 1. Variables and the related items that measure them.

Variables	Code	Items
Clarity of standards	CES1	The e-PA process requires my performance expectations to be set for me during a Planning Session at the start of a rating period.
	CES2	The e-PA process ensures that my performance expectations measure what I really do for the organization.
	CES3	The expectations set during the Performance Planning Session reflect the most important aspects of my job.
	CES4	The e-PA appraisal process allows me to help setting the standards that my supervisor will use to rate my performance.
	CES5	My performance standards set in the Planning Session can be changed if my tasks change.
	CES6	My rater clearly explains to me what he or she expects from my performance.
	CES7	My rater clearly explains to me the standards that will be used to evaluate my work.
	CES8	My rater gives me a chance to question how I should meet my performance expectations.
	CES9	My rater explains how I can improve my performance.
	CES10	My rater reviews with me my progress towards my goals.
	CES11	My rater reviews my performance expectations from the Performance Planning Session at least every three months in unofficial rating sessions
	CES12	The performance standards set for me during the Planning Session will remain the same until my rater and I decide to change them
Confidence on rater	COR1	My performance rating is based on how well I do my work.
	COR2	My performance rating reflects how much work I do.
	COR3	My performance rating is based on the many things I do that help at work.
	COR4	My most recent performance rating is based on the effort I spent on fulfilling my tasks.
	COR5	The most recent performance rating I received is based on my responsibilities at work.
	COR6	My performance rating is based on how well I do my work.
Seeking666666Appeal	SA1	I have the possibility to appeal a performance rating that I consider biased or inaccurate.
	SA2	I know I will be given a fair performance review rating if I request one.
	SA3	I can challenge a performance rating if I think it is unfair.
	SA4	I am comfortable in communicating my feelings of disagreement about my rating to my supervisor.
	SA5	A process to appeal a rating is available to me anytime I may need it.
	SA6	My performance rating can be changed if I can show that it is incorrect or unfair.
Rater competence	RC1	My organization makes sure that I am assigned a rater who is qualified to evaluate my work.
	RC2	My organization ensures that I am assigned a rater who knows what tasks I am performing.
	RC3	My organization makes sure that I am assigned a rater who understands the requirements and difficulties of my work.
	RC4	My organization makes sure that my rater is familiar with the e-PA rating procedures and rating format.
	RC5	My organization makes sure that I am assigned a rater that knows how to evaluate my performance.
Reaction to last rating	RLRS1	My organization makes sure that I am assigned a rater that knows how to evaluate my performance
	RLRS2	Overall, I am satisfied with the quality of the supervision I receive at work from my rater
	RLRS3	All in all, I have a good supervisor
	RLRS4	I would give my supervisor a positive rating
	RLRS5	My supervisor takes the rating system and process seriously
	RLRS6	I am satisfied with the performance rating I received for the most recent rating period
	RLRS7	My most recent performance rating was fair
	RLRS8	My most recent performance rating reflected the tasks I performed
	RLRS9	The performance rating, I received was pretty accurate
Accuracy of rating	AR1	My performance rating is based on how well I do my work.
	AR2	My performance rating reflects how much work I do.
	AR3	My performance rating is based on the many tasks I fulfill at work.
	AR4	My most recent performance rating is based on the effort I put into the job.
	AR5	The most recent performance rating I received is based on my responsibilities during my work.
	AR6	My performance rating represents a true picture of my performance.

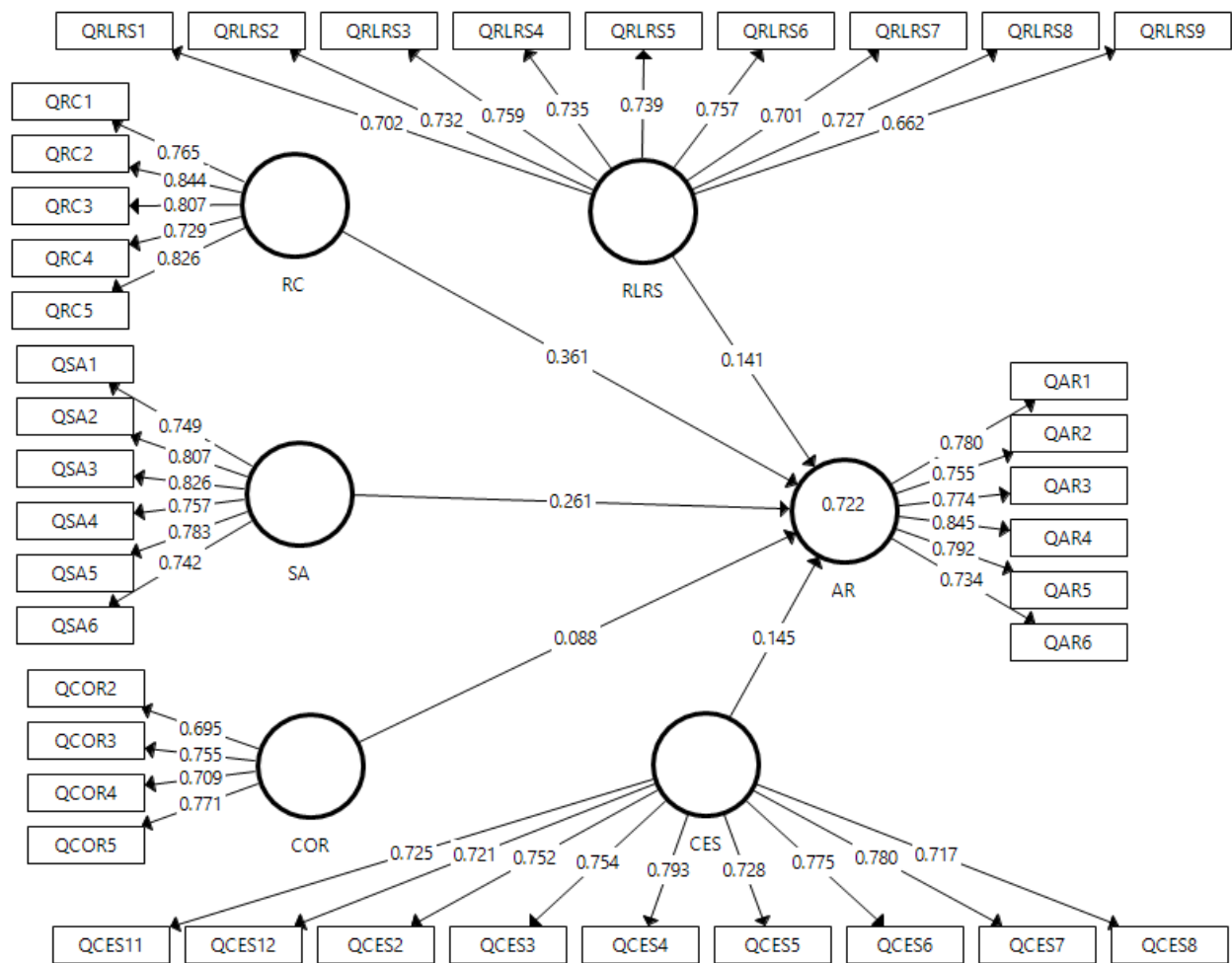

Figure 1. Measurement Model

4. Results

4.1. Measurement Model

4.1.1. Reliability

Reliability was measured by using Cronbach’s alpha and composite reliability methods (Table 2). All the Cronbach’s alpha values were higher than 0.7 indicating high internal consistency. The composite reliability values were above 0.8, ensuring a high degree of reliability.

Table 2. Construct Validity.

Variables	Cronbach’s Alpha	rho_A	Composite Reliability	(AVE)
AR	0.871	0.873	0.903	0.609
CES	0.903	0.905	0.920	0.562
COR	0.715	0.722	0.823	0.538
RC	0.854	0.858	0.896	0.632
RLRS	0.887	0.888	0.908	0.525
SA	0.869	0.872	0.902	0.606

4.1.2. Validity

The Convergent validity was determined by using =Average Variance Extracted (AVE). All values in the given tables are higher than 0.5 (Table 2) and thus considered to

be valid. Discriminant validity was measured through Fornell and Larcker [49] criterion and Heterotrait-Monotrait (HTMT) Ratio as proposed by Henseler, et al. [50]. Following the Fornell-Larcker criterion a construct should better explain the variance of its own indicator rather than the variance of other latent constructs [51]. Therefore, each construct has a greater value than the correlations of other constructs confirming high discriminant validity (Table 3). Using (HTMT) criterion all values above 0.9 show a lack of discriminant validity [52] which is not the case for the values in Table 4. Additionally, VIF statistics ruled out the possibility of data multicollinearity. All the VIF values are well below five, ruling out multicollinearity (Table 5).

Table 3. Discriminant Validity (Fornell-Larcker Criterion).

Variables	AR	CES	COR	RC	RLRS	SA
AR	0.781					
CES	0.666	0.750				
COR	0.612	0.525	0.734			
RC	0.774	0.572	0.586	0.795		
RLRS	0.671	0.731	0.567	0.607	0.725	
SA	0.757	0.633	0.599	0.740	0.596	0.778

Table 4. Discriminant Validity (Heterotrait-Monotrait Ratio).

Variables	AR	CES	COR	RC	RLRS
AR					
CES	0.746				
COR	0.766	0.652			
RC	0.895	0.642	0.747		
RLRS	0.761	0.812	0.715	0.694	
SA	0.868	0.709	0.753	0.855	0.676

Table 5. Collinearity Statistics (VIF).

Variables	AR
AR	
CES	2.478
COR	1.813
RC	2.525
RLRS	2.532
SA	2.719

4.2. Structural Model

The correlation matrix indicates positive relationships among variables. AR and all other variables are strongly correlated. CES and RLRS, CES and SA, RC and RLRS, and RC and SA are also strongly correlated (Table 6). However, CES and COR, CES and RC, COR and RC, COR and RLRS, COR and SA, RLRS are only moderately correlated. Since no correlation coefficient is beyond 0.8, auto-correlation is ruled out.

Table 6. Correlation Matrix.

Variables	AR	CES	COR	RC	RLRS	SA
AR	1					
CES	0.666	1				
COR	0.612	0.525	1			
RC	0.774	0.572	0.586	1		
RLRS	0.671	0.731	0.567	0.607	1	
SA	0.757	0.633	0.599	0.740	0.596	1

As far as cause-and-effect relationship is concerned the coefficient of determination shows that 72% endogenous variable variation is explained by the given exogenous variable (Table 7).

Table 7. R Square.

Variable	R Square	R Square Adjusted
AR	0.722	0.718

The review of path coefficient reveals that all the hypotheses are substantiated (Table 8, Figure 2). The H1 hypothesis (assumption that clarity in expectations and standards enhance the perception of accuracy of e-PA) is accepted and significant at $p = 0.05$. T statistics (2.656) also confirm that the value is larger than 1.645, indicating that the outer model loading is significant. The path coefficient (0.145) denotes a positive impact of CES on AR.

Table 8. Path Coefficient.

Variables	Original Sample (O)	Sample Mean (M)	Standard Deviation (STDEV)	T Statistics (O/STDEV)	p-Value
CES -> AR	0.145	0.144	0.054	2.656	0.004
COR -> AR	0.088	0.094	0.050	1.744	0.041
RC -> AR	0.362	0.357	0.068	5.288	0.000
RLRS -> AR	0.141	0.145	0.062	2.274	0.012
SA -> AR	0.261	0.257	0.061	4.257	0.000

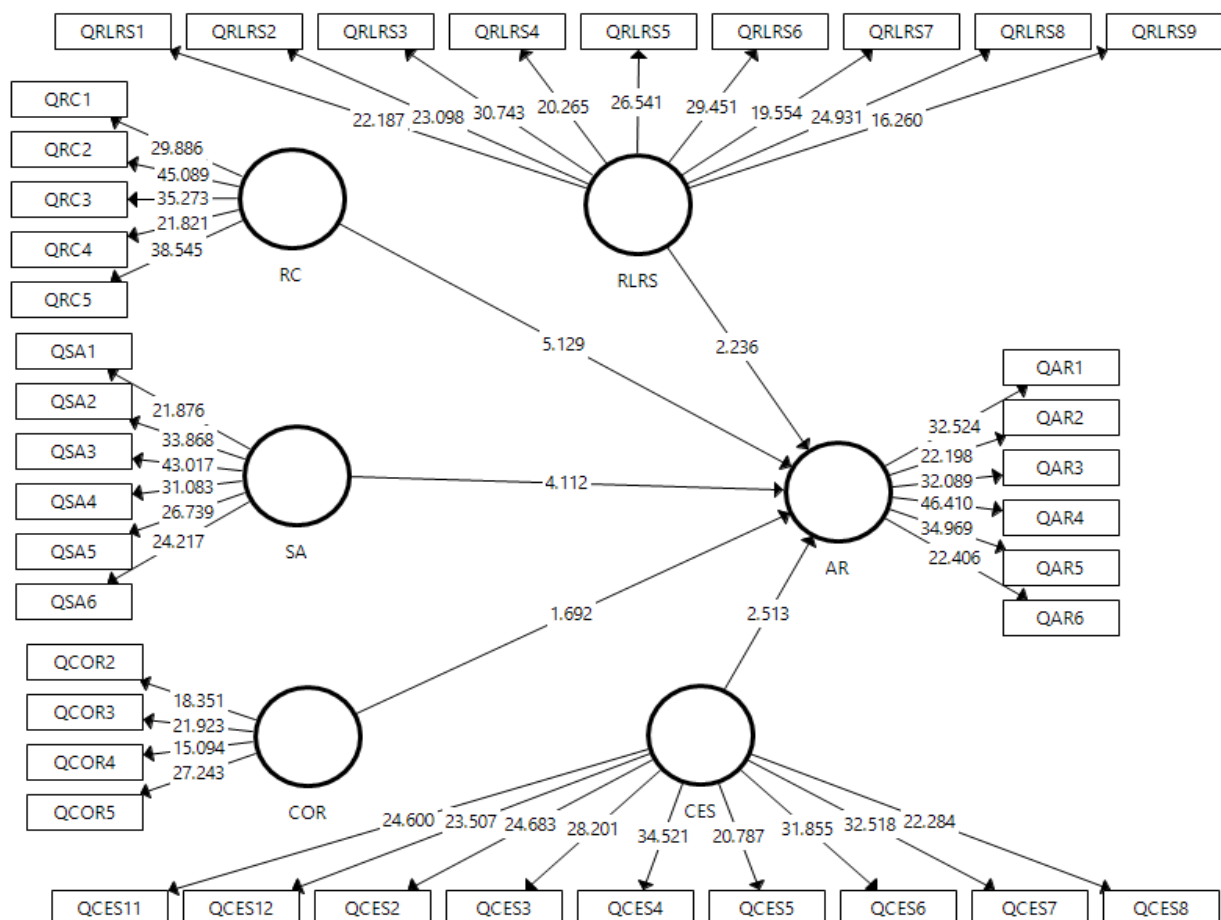

Figure 2. Structural model

H2 is barely accepted. Confidence over rater (COR) has a positive impact on the perception of accuracy of rating (AR). However, the path coefficient (0.088) is below 0.10, and thus considered to represent a weak relationship. *T* statistics (1.744) are just below the cutoff value (1.645) indicating that outer model loading is significant.

H3 is firmly substantiated. Rater confidence (RC) significantly impacts the employee's perception of the accuracy of rating (AR). The path coefficient (0.362) is strong enough to explain the variation in the dependent variable. *T* statistics (5.288) is significantly higher than the cutoff value (1.645) ensuring that the outer model loading is relevant enough.

H4 is accepted. Reaction to last rating and rater positively affects the employee's perception of the accuracy of e-performance appraisals. Even if significant at $p = 0.05$, the path coefficient (0.141) value indicates a moderate impact. *T* statistic is large enough to confirm the significance of the outer loading of the model.

H5 is accepted and path coefficient (0.261) denotes a strong impact of the availability of appeal against perceived unfairness and inaccuracy on perceived accuracy of e-PA. It is significant at $p = 0.05$ and *T* statistic (2.274) is much higher than the cutoff value, confirming that the outer loading of the model is significant.

5. Discussion

PA is a key practice in HR providing important organizational outcomes. A PA can provide the intensity of the contribution of an employee to organizational goals [53]. The change from traditional HRM to a web based technological approach has significantly changed and the design of HR practices and the employee's perceptions regarding HR practices. The motivation of this transformation is to enhance the degree of objectivity and accuracy in HR practices [54]. Additionally, PA provides essential information for crucial organizational decision-making. Decisions on compensation, training programs, job analysis, hiring, and standards settings and processes usually rely on PA reports. Performance appraisal is correlated with the employee's attitudes at work, his/her perception of organizational justice, and his/her motivation and commitment [55].

Once the importance of PA is established the question of authenticity of performance appraisal arises [56]. An incorrect performance appraisal report will lead to incorrect decisions. E-PA brings accuracy and reduces bias to HR practices when compared to traditional PA. IT enabled PMS, allows for the integration of strategies, policies, and practices of the organization with the performance management process [57].

Employees provide a good evaluation of the accuracy of performance rating because they best know how well they have performed their tasks [28]. A doubtful and negating attitude of employees towards the accuracy of PA can affect the whole PA system [58]. Neutrality and effectiveness of the PA systems depends not only on their technical reliability and validity but also on the employee's reaction [59]. Therefore, it is imperative for HR managers to ensure the employees' approval of the e-PA system to be implemented.

The present study explains how employees evaluate the accuracy of e-PA and the aspects that employees consider while evaluating the accuracy of e-PA rating. In our statistical reports the independent variables account for a 72% variation of the independent variable. Data analysis reveals that employees consider the competence of the rater the most important aspect of the evaluation. Obviously, the more knowledge and skills the rater possesses, the less the chances that he makes a mistake. Path coefficient (0.362) with the significance level at $p = 0.000$ denotes a cause and effect relationship between rater competence and perception of accuracy of e-PA, which is the strongest in the model. To the best of our knowledge literature on perceived accuracy of e-PA is not available. However, this result is consistent with the results obtained for traditional PA systems [60–62]. In traditional PA more emphasis was usually placed on accuracy and fairness [40,60,62,63] while in e-PA more emphasis has been placed on rater competence.

Respondents attached the second highest importance to the possibility to appeal when they feel that the rating is not correct or is biased. As a consequence, the employees are given the opportunity to review their performance rating when they feel it is unfair and

can obtain a reevaluation. Additionally, the rater becomes more responsible for his rating as the appeals will highlight any deficiency from his side. The relationship is statistically significant at $p = 0.000$ and the strength of the relationship is 0.261 as per the path coefficient. This result is consistent with the literature concerning traditional PA system [39,64,65] and reinforces the validity of the Equity theory [29].

Clear communication of expectations and standards also enhances the employee perception of accuracy of e-performance rating. Role ambiguity and lack of clarity in standards can cause a lack of involvement of the employees on their performance evaluation. Conversely, when the standards are clear to the employees, they are more prone to dedicate efforts towards the expected p (performance). The relationship between clarity of expectations and standards and perception of accuracy of e-PA is significant at $p = 0.004$ and the coefficient of the relationship is 0.145 as regressed. The findings are consistent with traditional PA literature [66–68] even if the given relationship is not as strong. Based on the argument in Expectancy theory [30] expectations and standards towards a particular goal will motivate employees to put in their efforts. Likewise, employees want to know the expectations to rightly direct their performance.

Reaction to last rating and rater also influence the perception of the accuracy of e-PA even if the relationship is moderate. If the last period appraisal is not perceived as fair, the employees will expect the same lack of fairness in the next evaluations. The hypothesized relationship is significant at $p = 0.012$ and the coefficient of regression is 0.141. This result is consistent with existing literature on the traditional PA system [1,39,63,64] and the theoretical base provided by feedback intervention theory [31].

The relationship between confidence over rater and perception of accuracy of e-PA is barely accepted. The T value (1.744) and the significance $p = 0.041$ is just beyond the borderline. The strength of the relationship, 0.088, is weak. This is the most interesting and unexpected finding. The result is not consistent with the literature results about traditional PA which points at the employees being concerned by the confidence over rater [39,40,60,65,66]. Furthermore, results are not really consistent with the basic assumption of Equity Theory which states that employees are concerned by the fairness of the PA systems. Anyway, the introduction of electronic technologies in PA systems minimizes the subjective interference of the rater to some extent. On the other hand, the possibility to appeal against the ratings also decreases the occurrence of biased ratings.

6. Contributions and Recommendations

This study yields a mix of expected and unexpected results. Findings reveal that employees are concerned by the rater's competence. In traditional PA, system competence of rater is not that important to the employees [69,70]. It is evident that the introduction of new technology has increased the complexity of the system which now requires more knowledge and skills from managers and employees. Therefore, a rater is expected to possess IT skills in addition to his traditional PA knowledge.

Another major theoretical contribution of our study is that employees are surprisingly not much concerned by the fairness and justice of e-PA systems. Previous studies showed a strong relationship between the employees' perception of fairness and the perception of accuracy of the PA [40,60]. This is explained by the fact that the data processing functions, and the information sharing are carried out electronically. And this is perceived as ensuring a good degree of objectivity which minimizes bias occurrence. Additionally, the possibility to appeal against unfair evaluation is another reason for this lack of concern. Clear communication of standards and availability of the office where appeal can be filed against unfair appraisal were equally emphasized by respondents. This is consistent with the previous results [40,60,61]

Keeping in mind the significance of performance appraisal for both management and employees, we briefly extend the following recommendations:

1. Organizations need to transform their performance management system, particularly their PA system by introducing an IT based PA system. E-PA is more objective, fair, accurate, easy to access, and timely than traditional PAs.
2. Setting standards and a fluid communication of these standards to the employee, as well as to the rater, is of high importance. It enables the rater to be more objective and accurate. It also enables the employees to improve their performance.
3. Choosing the right person for conducting e-PAs is crucial. The candidate has to possess multidimensional knowledge and skills. His tasks involve performance appraisal activities as well as IT knowledge. A proper and objective training for the raters requires Training Needs Analysis.
4. Employees have the right to disagree with their evaluation. The study revealed that the possibility to review their evaluation and appeal against their rating is important to the employees and improves the employees' opinion of the accuracy of e-PA and results in improved performance.

7. Conclusions

The employee perception of accuracy of performance evaluation plays a vital role in validating the entire performance management process. Many strategic decisions are directly or indirectly linked with performance reports. It is very important to ensure the quality of performance appraisal reports in order to enable managers to make timely and correct decisions. IT integration in HR management produces better outcomes. E-HRM is promoting an organizational transformation. Web and computer-based PAs provide relatively unbiased, correct, and timely information and enables managers to make correct and timely decisions.

Five hypotheses were tested using structural equation modeling. The results confirmed that the employees were particularly concerned by the competence of the rater. Enabling employees to disagree with performance ratings perceived as unfair or inaccurate and getting the performance appraisal reviewed brings positive outcomes to the workers performance. Clear communication of expectations and standards is also important because it keeps employees on the right track. It enables the rater to provide objective and timely feedback to employees to correct their possible deviances from the expected performance. Assigning the right person for the e-performance evaluation, providing the possibility to review a rating, and the clarity of expectations and standards to both the rater and the employee profoundly affect the employees' perception of accuracy of e-PA. When these three conditions are fulfilled employees are less concerned by the rater attitude and the period performance analysis. Results also revealed that under the e-PA system employees are less worried by bias and unfair evaluations.

It is of paramount importance for organizations to change their traditional performance management system to an electronic and web technology based one to gain accuracy in their evaluations. Organizations now require HR personnel with interdisciplinary skills such as computer and web-based skills.

Author Contributions: All of the authors contributed to conceptualization, formal analysis, investigation, methodology and writing and editing the original draft. All authors have read and agreed to the published version of the manuscript.

Funding: This research received no external funding.

Institutional Review Board Statement: Not applicable.

Informed Consent Statement: Informed consent was obtained from the respondents of the survey.

Data Availability Statement: The data will be made available on request from the corresponding author.

Acknowledgments: The authors acknowledge the efforts of anonymous reviewers in evaluating the current study and mentioning the weak areas. The authors also acknowledge the support and efforts of the worthy editor during this research journey.

Conflicts of Interest: The authors declare no conflict of interest.

References

- Ledford, G.E.; Benson, G.; Lawler, E.E. Aligning research and the current practice of performance management. *Ind. Organ. Psychol.* **2016**, *9*, 253–260. [[CrossRef](#)]
- Berber, N.; Đorđević, B.; Milanović, S. Electronic human resource management (e-HRM): A new concept for digital age. *Strateg. Manag.* **2018**, *23*, 22–32. [[CrossRef](#)]
- Delery, J.E.; Roumpis, D. Strategic human resource management, human capital and competitive advantage: Is the field going in circles? *Hum. Resour. Manag. J.* **2017**, *27*, 1–21. [[CrossRef](#)]
- Rondeau, K.V. Chapter 12: E-Performance and reward management. In *e-HRM: Digital Approaches, Directions & Applications*, 1st ed.; Thite, M., Ed.; Routledge: Milton Park, UK, 2018.
- Bondarouk, T.; Parry, E.; Furtmueller, E. Electronic HRM: Four decades of research on adoption and consequences. *Int. J. Hum. Resour. Manag.* **2017**, *28*, 98–131. [[CrossRef](#)]
- Fisher, C.D.; Schoenfeldt, L.; Shaw, J. *Advanced Human Resource Management*; Houghton Mifflin Customer Publishing: Boston, MA, USA, 2006; p. 238.
- Bondarouk, T.V.; Ruël, H.J.M. Electronic Human Resource Management: Challenges in the digital era. *Int. J. Hum. Resour. Manag.* **2009**, *20*, 505–514. [[CrossRef](#)]
- Strohmeier, S. Research in e-HRM: Review and implications. *Hum. Resour. Manag. Rev.* **2007**, *17*, 19–37. [[CrossRef](#)]
- Stone, D.L.; Deadrick, D.L.; Lukaszewski, K.M.; Johnson, R. The influence of technology on the future of human resource management. *Hum. Resour. Manag. Rev.* **2015**, *25*, 216–231. [[CrossRef](#)]
- Voermans, M.; van Veldhoven, M. Attitude towards E-HRM: An empirical study at Philips. *Pers. Rev.* **2007**, *6*, 887–902. [[CrossRef](#)]
- Ruël, H.; Bondarouk, T.; Loise, J.K. E-HRM: Innovation or irritation. An explorative empirical study in five large companies on web-based HRM. *Manag. Rev.* **2004**, *15*, 364–380.
- Kovach, K.A.; Hughes, A.A.; Fagan, P.; Maggitti, P.G. Administrative and strategic advantages of HRIS. *Employ. Relat. Today* **2002**, *29*, 43–48. [[CrossRef](#)]
- Schneider, B.; Brief, A.P.; Guzzo, R.A. Creating a climate and culture for sustainable organizational change. *Organ. Dyn.* **1996**, *24*, 7–19. [[CrossRef](#)]
- Meijerink, J.; Bondarouk, T. Exploring the central characteristics of HR shared services: Evidence from a critical case study in the Netherlands. *Int. J. Hum. Resour. Manag.* **2013**, *24*, 487–513. [[CrossRef](#)]
- Chung, B.G.; Schneider, B. Serving multiple masters: Role conflict experienced by service employees. *J. Serv. Mark.* **2002**, *16*, 70–87. [[CrossRef](#)]
- Bondarouk, T.; Furtmueller, E. Electronic human resource management: Four decades of empirical evidence. *Acad. Manag. Proc.* **2012**, *2012*, 15668. [[CrossRef](#)]
- Marler, J.H.; Fisher, S.L. An evidence-based review of e-HRM and strategic human resource management. *Hum. Resour. Manag. Rev.* **2013**, *23*, 18–36. [[CrossRef](#)]
- Ruël, H.; Bondarouk, T. E-HRM research and practice: Facing the challenges ahead. In *Handbook of Strategic e-Business Management*; Martínez-López, F., Ed.; Springer: Berlin, Germany, 2014; pp. 633–653. [[CrossRef](#)]
- Van Geffen, C.; Ruël, H.; Bondarouk, T. E-HRM in MNCs: What can be learned from a review of the IS literature? *Eur. J. Int. Manag.* **2013**, *7*, 373–392. [[CrossRef](#)]
- Bondarouk, T.; Ruël, H. The strategic value of e-HRM: Results from an exploratory study in a governmental organization. *Int. J. Hum. Resour. Manag.* **2013**, *24*, 391–414. [[CrossRef](#)]
- Gardner, S.D.; Lepak, D.P.; Bartol, K.M. Virtual HR: The impact of information technology on the human resource professional. *J. Vocat. Behav.* **2003**, *63*, 159–179. [[CrossRef](#)]
- Olivas-Lujan, M.R.; Ramirez, J.; Zapata-Cantu, L. e-HRM in Mexico: Adapting innovations for global competitiveness. *Int. J. Manpow.* **2007**, *28*, 418–434. [[CrossRef](#)]
- Cooper, D.R.; Blumberg, B.; Schindler, P.S. *Business Research Methods*; McGraw Hill: London, UK, 2005; p. 116.
- Mohammed, A. The impact of talent management on employee engagement, retention and value addition in achieving organizational performance. *Int. J. Eng. Manag.* **2016**, *1*, 142–152.
- Frayne, C.; Lockwood, D.L.; Stephenson, H.; Geringer, J.M. The impact of contingent time off on productivity in a small manufacturing environment. *J. Manag. Mark. Res.* **2010**, *3*, 1.
- Dowling, G.R. *Corporate Reputations: Strategies for Developing the Corporate Brand*; Kogan Page: Melbourne, Australia, 1994; p. 261.
- Davis, F.D. Perceived usefulness, perceived ease of use, and user acceptance of information technology. *MIS Q.* **1989**, *13*, 319–340. [[CrossRef](#)]
- Hulland, J. Use of partial least squares (PLS) in strategic management research: A review of four recent studies. *Strateg. Manag. J.* **1999**, *20*, 195–204. [[CrossRef](#)]
- Hair, J.F., Jr.; Sarstedt, M.; Hopkins, L.; Kuppelwieser, V.G. Partial least squares structural equation modeling (PLS-SEM). *Eur. Bus. Rev.* **2014**, *26*, 106–121. [[CrossRef](#)]

30. Gold, S.; Heesen, C.; Schulz, H.; Guder, U.; Mönch, A.; Gbadamosi, J.; Buhmann, C.; Schulz, K. Disease specific quality of life instruments in multiple sclerosis: Validation of the Hamburg Quality of Life Questionnaire in Multiple Sclerosis (HAQUAMS). *Mult. Scler. J.* **2001**, *7*, 119–130. [[CrossRef](#)]
31. Sheehan, M. Human resource management and performance: Evidence from small and medium-sized firms. *Int. Small Bus. J.* **2014**, *32*, 545–570. [[CrossRef](#)]
32. Galanaki, E.; Lazazzara, A.; Parry, E. A cross-national analysis of e-HRM configurations: Integrating the information technology and HRM perspectives. In *Organizing for Digital Innovation. Lecture Notes in Information Systems and Organisation*; Lazazzara, A., Nacamulli, R., Rossignoli, C., Za, S., Eds.; Springer: Cham, Switzerland, 2019; pp. 261–276.
33. Mozgovoy, V.; Mettler, T. Effectiveness of Electronic Human Resource Management in Public Service: A Systematic Literature Review. In *Proceedings of the European Group for Public Administration Conference (EGPA)*, Lausanne, Switzerland, 7 September 2018.
34. Payne, S.C.; Mendoza, A.M.; Horner, M.T. Electronic Performance Management. In *The Brave New World of eHRM 2.0*; Stone, D.L., Dulebohn, J.H., Eds.; Information Age: Charlotte, NC, USA, 2018; pp. 189–215.
35. Al-Raisi, A.; Amin, S.; Tahir, S. Evaluation of e-performance analysis and assessment in the United Arab Emirates (UAE) Organizations. *J. Internet Inf. Syst.* **2011**, *2*, 20–27.
36. Ahmed, A.; Ogalo, H.S. From hrm to e-hrm: Contemporary developments from scholarly work. *Ann. Contemp. Dev. Manag.* **2019**, 2632–7686. [[CrossRef](#)]
37. Park, S.; Choi, S. Performance Feedback, Goal Clarity, and Public Employees' Performance in Public Organizations. *Sustain.* **2020**, *12*, 3011. [[CrossRef](#)]
38. Labuschagne, C.; Brent, A.C.; Van Erck, R.P. Assessing the sustainability performances of industries. *J. Clean. Prod.* **2005**, *13*, 373–385. [[CrossRef](#)]
39. Adams, J.S. Inequity in social exchange. In *Advances in Experimental Social Psychology*, Berkowitz, L., Ed.; Elsevier: Amsterdam, The Netherlands, 1965; Volume 2, pp. 267–299. [[CrossRef](#)]
40. Vroom, V.H. *Motivation in Management*; American Foundation for Management Research: New York, NY, USA, 1965; p. 313.
41. Kluger, A.N.; DeNisi, A. The effects of feedback interventions on performance: A historical review, a meta-analysis, and a preliminary feedback intervention theory. *Psychol. Bull.* **1996**, *119*, 254. [[CrossRef](#)]
42. Lunenburg, F.C. Goal-setting theory of motivation. *Int. J. Manag. Bus., Adm.* **2011**, *15*, 1–6.
43. Dangol, P. Role of Performance Appraisal System and Its Impact on Employees Motivation. *Quant. Econ. and Manag. Stud.* **2021**, *2*, 13–26. [[CrossRef](#)]
44. Locke, E.A.; Latham, G.P. A theory of goal setting and task performance. *Acad. of Manag. Rev.* **1991**, *16*, 480–483. [[CrossRef](#)]
45. Klein, H.J. Control theory and understanding motivated behavior: A different conclusion. *Motiv. Emot.* **1991**, *15*, 29–44. [[CrossRef](#)]
46. Zhou, J. When the presence of creative coworkers is related to creativity: Role of supervisor close monitoring, developmental feedback, and creative personality. *J. Appl. Psychol.* **2003**, *88*, 413. [[CrossRef](#)]
47. Taylor, M.S.; Fisher, C.D.; Ilgen, D.R. Individual's reactions to performance feedback in organizations: A control theory perspective. In *Research in Personnel and Human Resources Management*; JAI Press: Stamford, CT, USA, 1984; pp. 81–124.
48. Sudin, S. Fairness of and satisfaction with performance appraisal process. *J. Glob. Manag.* **2011**, *2*, 66–83.
49. Krishnan, R.; Ahmad, B.; Farihah, N.A.; Haron, H. The Effect of Employees' Perceived Fairness of Performance Appraisal Systems on Employees' Organizational Commitment. *Int. J. Acad. Res. Bus. Soc. Sci.* **2018**, *8*, 448–465.
50. Gu, F.; Nolan, J.; Rowley, C. Organizational justice in Chinese banks: Understanding the variable influence of guanxi on perceptions of fairness in performance appraisal. *Asia Pac. Bus. Rev.* **2020**, *26*, 169–189. [[CrossRef](#)]
51. Beer, M. The technology of organization development. In *Handbook of Industrial and Organizational Psychology*; Dunnette, M.D., Ed.; Rand McNally: Chicago, IL, USA, 1976; pp. 937–994.
52. Ahmad, R.; Ismail, A.; Ismail, W.K.W. Sistem penilaian prestasi sektor awam di Malaysia: Pemikiran semula terhadap peranan dan tanggungjawab pegawai penilai prestasi. *J. Kemanus.* **2007**, *5*.
53. Cleveland, J.N.; Murphy, K.R. Analyzing performance appraisal as goal-directed behavior. *Res. Pers. Hum. Resour. Manag.* **1992**, *10*, 121–185.
54. Tziner, A.; Levy, S. Examination of Performance Appraisal Behavior Structure. *Front. Psychol.* **2017**, *7*, 2075. [[CrossRef](#)]
55. Kwon, H.W. Performance Appraisal Politics in the Public Sector: The Effects of Political Skill and Social Similarity on Performance Rating. *Public Pers. Manag.* **2020**, *49*, 239–261. [[CrossRef](#)]
56. Iqbal, M.Z.; Akbar, S.; Budhwar, P.; Shah, S.Z.A. Effectiveness of performance appraisal: Evidence on the utilization criteria. *J. Bus. Res.* **2019**, *101*, 285–299. [[CrossRef](#)]
57. Waheed, A.; Abbas, Q.; Malik, O.F. 'Perceptions of performance appraisal quality' and employee innovative behavior: Do psychological empowerment and 'perceptions of HRM system strength' matter? *Behav. Sci.* **2018**, *8*, 114. [[CrossRef](#)] [[PubMed](#)]
58. Fornell, C.; Larcker, D.F. Structural equation models with unobservable variables and measurement error: Algebra and statistics. *J. Mark. Res.* **1981**, *18*, 382–388. [[CrossRef](#)]
59. Henseler, J.; Ringle, C.M.; Sarstedt, M. A new criterion for assessing discriminant validity in variance-based structural equation modeling. *J. Acad. Mark. Sci.* **2015**, *43*, 115–135. [[CrossRef](#)]
60. Buchner, T.W. Performance management theory: A look from the performer's perspective with implications for HRD. *Hum. Resour. Dev. Int.* **2007**, *10*, 59–73. [[CrossRef](#)]

61. Aureli, S.; Del Baldo, M. Performance appraisal of business networks. how small and medium enterprises define and monitor network objectives. *Manag. Control.* **2016**, *1*, 35–58. [[CrossRef](#)]
62. John Bernardin, H.; Thomason, S.; Ronald Buckley, M.; Kane, J.S. Rater rating-level bias and accuracy in performance appraisals: The impact of rater personality, performance management competence, and rater accountability. *Hum. Resour. Manag.* **2016**, *55*, 321–340. [[CrossRef](#)]
63. Barclay, J.H.; Harland, L.K. Peer performance appraisals: The impact of rater competence, rater location, and rating correctness on fairness perceptions. *Group Organ. Manag.* **1995**, *20*, 39–60. [[CrossRef](#)]
64. Anthony, C.J.; Styck, K.M.; Cooke, E.; Martel, J.R.; Frye, K.E. Evaluating the Impact of Rater Effects on Behavior Rating Scale Score Validity and Utility. *Sch. Psychol. Rev.* **2020**, 1–15. [[CrossRef](#)]
65. Elangovan, N.; Rajendran, S. Impact of functional interdependency on employee satisfaction with performance appraisal in the real estate industry. *Probl. Perspect. Manag.* **2021**, *18*, 213.
66. Clarke, N.; Alshenalfi, N.; Garavan, T. Upward influence tactics and their effects on job performance ratings and flexible working arrangements: The mediating roles of mutual recognition respect and mutual appraisal respect. *Hum. Resour. Manag.* **2019**, *58*, 397–416. [[CrossRef](#)]
67. Maiyaki, A.A.; Yaro, L.M. Mediating Effect of Organizational Justice on The Relationship Between Job Satisfaction and Performance Appraisal: A Pilot Study. *Int. J. Manag. Sci. Entrep.* **2020**, *19*. Available online: https://www.cambridgenigeriapub.com/wp-content/uploads/2021/01/CJMSE_Vol18_No7_Sept_2020-4.pdf (accessed on 16 December 2020).
68. Rubin, E.V.; Edwards, A. The performance of performance appraisal systems: Understanding the linkage between appraisal structure and appraisal discrimination complaints. *Int. J. Hum. Resour. Manag.* **2020**, *31*, 1938–1957. [[CrossRef](#)]
69. Ismail, H.N.; Rishani, M. The relationships among performance appraisal satisfaction, career development and creative behavior. *J. Dev. Areas* **2018**, *52*, 109–124. [[CrossRef](#)]
70. Blackman, D.A.; Buick, F.; O’Flynn, J.; O’Donnell, M.; West, D. Managing expectations to create high performance government. *Rev. Public Pers. Adm.* **2019**, *39*, 185–208. [[CrossRef](#)]