

Improvement of EV Maneuverability and Safety by Dynamic Force Distribution with Disturbance Observer

Peng He*, Yoichi Hori**

Multi-wheel driven EV is referred to as an over-actuated system in the motion control synthesis process. It is meaningful to use the redundant actuators to maintain the control reliability and thus improve the dynamics of EV. In this paper, a dynamic optimum force distribution method which utilizes redundant motors is discussed. Besides, we also mention a disturbance observer to estimate the tire friction conditions. Incorporated with active yaw moment control, the proposed method is evaluated by the experiments. The results show the proposed method can improve dynamics and keep handling stability of the EV.

Keywords: Dynamic force distribution, motion control, disturbance observer, electric vehicle

1. INTRODUCTION

For the reason of environmental protection and energy conservation, researches about electric vehicle (EV) have been put forward greatly in recent years.

In-wheel motored EV is a newly developed vehicle. As Fig.1 shows, the driving electric motors are installed into wheels. That motored wheel can be controlled independently [1]. Based on this kind of configuration, it is easy to perform force control directly and realize complexity motion control without traditional power train or mechanical parts. Therefore, it inevitably stimulates the researches about the “by-wire” control.

Multi-in-wheel driven EV is looked on as an over actuated system. It is meaningful to take advantage of redundant in-wheel motors to improve control reliability and dynamics of that kind of EVs.

Since that, EVs must be controlled much more adaptable than before.

Force control of motored wheels is the basement for all advanced motion control strategies. To obtain an optimum “force control” by using all of the controllable driving motors, which include redundant ones, is the main theme of dynamic force distribution.

For the next generation EVs, there is a potential requirement for the development of dynamic force distribution control, which has properties of dependable, adaptable and optimizable [8]. However there are fewer researches on this topic. So far there is even no practical application of this research to be realized on a multi-in-wheel driven EV.

In this paper, we discuss a dynamic force distribution method and apply it by incorporating with the

maneuverability assistant control system, which is well known as active yaw moment control.



Fig. 1 “UOT March II” and its in-wheel motors

By optimal force control of motored wheels, traction force between tire and road could be generated instantly. Due to such precise traction force generation, yaw moment, which effects EV yaw rate, can be controlled exactly [2]. We will use this active controllable yaw moment to improve maneuverability and keep safety throughout yaw rate control.

Normally, the active yaw moment can be obtained by only controlling two motored wheels on the different sides of EV. However, if all wheels are motored, the same yaw moment can be obtained by force control of different groups of motored wheels.

When EV drives in a critical or dangerous road condition, the redundant driving motors can be used for avoiding the tire slip or wheel lock. In other case, for example, when one motored wheel suddenly fails and can not produce the nominal control effect, the redundant ones can be used to make up the difference and prevent controllability from degrading.

* Department of Electrical Engineering, the University of Tokyo, 4-6-1 Komaba, Meguro, Tokyo 153-8505, Japan, e-mail: ka@horilab.iis.u-tokyo.ac.jp

** Institute of Industrial Science, the University of Tokyo, 4-6-1 Komaba, Meguro, Tokyo 153-8505, Japan, e-mail: hori@iis.u-tokyo.ac.jp

To use the redundant motors, tire working conditions should be well considered. Although many kinds of expensive sensors can be used for the detection of tire friction forces, it is difficult to clearly know that values in real time. Therefore, in this paper we also propose an estimation method based on a disturbance observer.

The remainder of this paper is organized as follows: section 2 mentions the analysis of vehicle dynamic; section 3 discusses estimation of tire friction force; section 4 mentions dynamic force distribution; section 5 mentions the evaluation of force distribution integrated with active yaw moment control; section 6 mentions conclusions and future works.

2. VEHICLE DYNAMIC ANALYSIS

As an example of multi-wheel-driven EV, a four-wheel-driven EV is studied in this paper. The free body diagram is shown in Fig. 2.

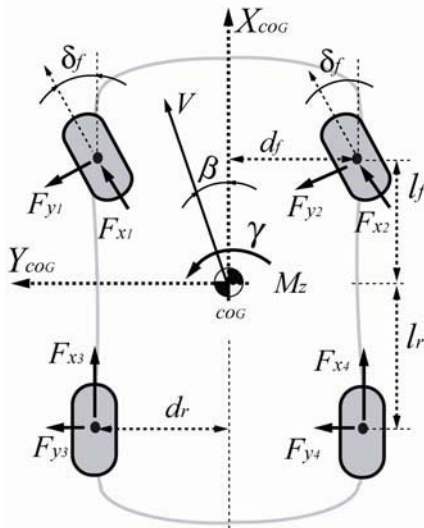

Fig. 2 Free body diagram of four-wheel driven EV

The proposed method will be evaluated by the experiments of the yaw rate control. Therefore, it is natural to consider the horizontal motion of EV. We assume that the front steering is controlled by the driver. The steering angles of left and right sides are equal. Four motored wheels can be controlled independently. We also assume that the front steering angle δ_f and side slip angle β of EV body are very small. The EV dynamics can be expressed as [3]

lateral dynamics

$$Ma_y = MV(\dot{\beta} + \gamma) = F_{y1} + F_{y2} + F_{y3} + F_{y4} \quad (1)$$

yaw motion around the vertical axis

$$J\dot{\gamma} = M_{zx} + M_{zy} = M_z \quad (2)$$

$$M_{zx} = d_f(F_{x2} - F_{x1}) + d_r(F_{x4} - F_{x3}) \quad (3)$$

$$M_{zy} = l_r(F_{x3} + F_{x4}) - l_f(F_{x1} + F_{x2}) \quad (4)$$

Where M is the vehicle mass; a_y is the lateral acceleration; γ is yaw rate; $d_f(d_r)$ is the front (rear) wheel thread; $l_f(l_r)$ is distance between the center of gravity and the front (rear) axis. V is the velocity of EV. $F_{x1}, F_{x2}, F_{x3}, F_{x4}$ are traction forces of tires. $F_{y1}, F_{y2}, F_{y3}, F_{y4}$ are lateral forces of tires.

2.1 Linear EV Model

The linear tire model is used for dynamic analysis. Therefore the lateral tire forces can be written as:

$$F_{yi} = -C_i\alpha_i; i = \{1,2,3,4\} \quad (5)$$

where C_i is the cornering power of the tire. α_i is the slip angle of the tire. Those variables are simplified as:

$$C_1 = C_2 = C_f; C_3 = C_4 = C_r$$

$$\alpha_f = \beta - \delta_f + \frac{l_f}{V}\gamma; \alpha_r = \beta - \frac{l_r}{V}\gamma;$$

In this paper, we also assume that the steering angle is small and the longitudinal velocity is constant. From Eq.1 to Eq.5, the linear dynamics of EV planar motion can be written as:

$$\begin{pmatrix} \dot{\beta} \\ \dot{\gamma} \end{pmatrix} = \begin{bmatrix} -\frac{2(C_f + C_r)}{MV} & -1 - \frac{2(l_f C_f - l_r C_r)}{MV^2} \\ -\frac{2(l_f C_f - l_r C_r)}{J} & -\frac{2(l_f^2 C_f + l_r^2 C_r)}{JV} \end{bmatrix} \begin{pmatrix} \beta \\ \gamma \end{pmatrix} \quad (6)$$

$$+ \begin{bmatrix} \frac{2C_f}{MV} & 0 \\ \frac{2l_f C_f}{J} & \frac{1}{J} \end{bmatrix} \begin{bmatrix} \delta_f \\ M_{zx} \end{bmatrix}$$

From Eq.6, the transfer functions from steering angle and yaw moment to yaw rate can be written as:

$$\gamma = \frac{G_r(1 + T_r s)}{1 + \frac{2\zeta_n}{\omega_n} s + \frac{1}{\omega_n^2} s^2} \delta_f + \frac{G_m(1 + T_m s)}{1 + \frac{2\zeta_n}{\omega_n} s + \frac{1}{\omega_n^2} s^2} M_{zx} \quad (7)$$

where G_r, G_m are steady gains. T_r, T_m are time constants. They are all defined by the vehicle structure parameters [4]. ζ_n is the damping coefficient. ω_n is the natural frequency of control system.

A reference model is defined for the section 5. We use the same method as what is discussed in [4]. According to Eq.7, the reference model is expressed as:

$$\gamma^* = \frac{G_r(1+T_r s)}{1 + \frac{2G_n}{\omega_n' s} + \frac{1}{\omega_n'^2 s^2}} \delta_f \quad (8)$$

where $\omega_n' > \omega_n$. In this study we define $\omega_n' = 1.5\omega_n$.

3. ESTIMATIONS

As mentioned above, it is necessary to know the tire friction conditions for dynamic force distribution.

It is well known that the tire friction forces, which are shown in Fig.3, satisfy:

$$F_x^2 + F_y^2 \leq \mu^2 F_z^2 \quad (9)$$

We use the measured longitudinal and lateral accelerations to estimate the normal forces acted on the wheels. Normal forces could be estimated in real time [6].

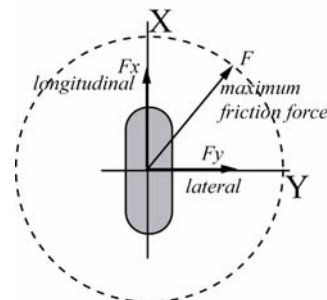

Fig. 3 Tire friction force

3.1 Traction Force on the Longitudinal Direction

The dynamics of motored wheel can be expressed as:

$$J_w' \frac{d\omega}{dt} = F_m - F_{dis}, \quad J_w' = \frac{J_w}{r_d}$$

Longitudinal friction force F_{dis} , which is also called traction force, can be derived by

$$F_{dis} = F_m - J_w' \frac{d\omega}{dt} \quad (10)$$

It is easy to estimate the traction force by a disturbance observer, which is show in Fig.4.

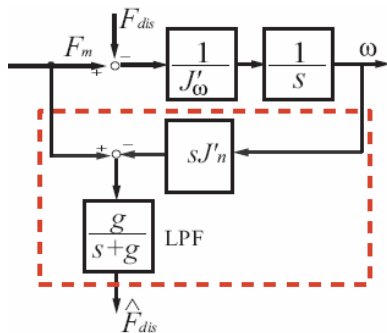

Fig.4 Disturbance observer estimating traction force

3.2 Force on the Lateral Direction

Yaw moment \hat{M}_{zx} , which is generated by the left and right traction forces, can also be estimated. The estimator is shown in Fig.5, which is a common idea in the researches of control of wheelchair [5].

Rewrite the Eq.1 and Eq.2 as follows

$$J \frac{d\gamma}{dt} = l_f F_{yf} - l_r F_{yr} + \hat{M}_{zx} \quad (11)$$

$$MV(\dot{\beta} + \gamma) = F_{yf} + F_{yr} \quad (12)$$

The front and rear lateral forces can be calculated as follows

$$\hat{F}_{yf} = \frac{1}{l} (l_r MV(\dot{\beta} + \gamma) + J\dot{\gamma} - \hat{M}_{zx}) \quad (13)$$

$$\hat{F}_{yr} = \frac{1}{l} (l_f MV(\dot{\beta} + \gamma) - J\dot{\gamma} + \hat{M}_{zx}) \quad (14)$$

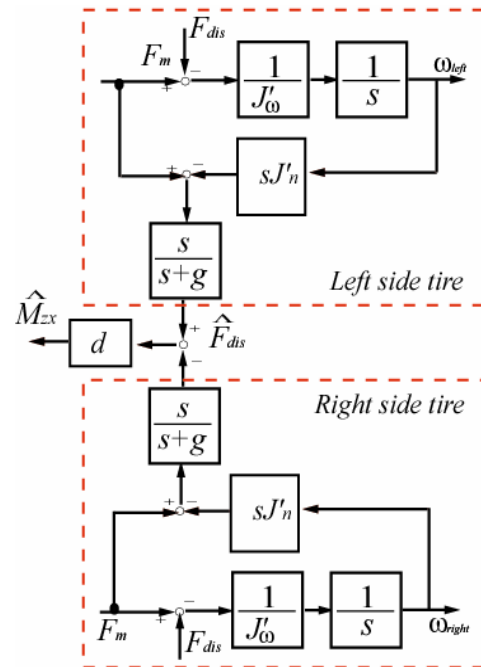

Fig.5: Estimation of yaw moment generated by left and right traction forces

In Eq.13 and Eq.14, deviation of side slip angle $\dot{\beta}$ can be obtained with the side slip angle estimation, which is published by [7]. According to Eq.6, the derivative variable $\dot{\beta}$ can be written as:

$$\begin{aligned} \dot{\beta} = & -\frac{2(C_f + C_r)}{MV} \hat{\beta} + \left(-1 - \frac{2(l_f C_f - l_r C_r)}{MV^2}\right) \gamma \\ & + \frac{2C_f}{MV} \delta_f \end{aligned} \quad (15)$$

In this study, we assume that the slip angles and road conditions of left and right tire are equal. We can get the lateral force of each tire as:

$$\hat{F}_{y1} = \frac{F_{z1}}{F_{z1} + F_{z2}} \hat{F}_{yf} ; \quad \hat{F}_{y2} = \frac{F_{z2}}{F_{z1} + F_{z2}} \hat{F}_{yf} \quad (16)$$

$$\hat{F}_{y3} = \frac{F_{z3}}{F_{z3} + F_{z4}} \hat{F}_{yf} ; \quad \hat{F}_{y4} = \frac{F_{z4}}{F_{z3} + F_{z4}} \hat{F}_{yf} \quad (17)$$

4. DYNAMIC FORCE DISTRIBUTION

4.1 Mathematic Statement of Dynamic Force Distribution

Dynamic force distribution is used to utilize the redundant driving motors. Normally, this kind of dynamic distribution is stated as a kind of inverse optimal control problem.

As for the inverse control problem, the control effectors, for example the total driving force or active yaw moment, are defined first. According to those required control effectors, control inputs of the system will be generated by the force distribution.

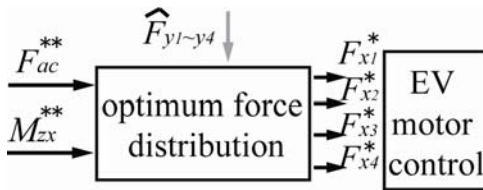

Fig. 6 Outline of dynamic force distribution

As Fig.6 shows, the control effectors are the required force (F_{ac}^{**}) and yaw moment (M_{zx}^{**}). F_{xi}^* are control inputs.

The objective of dynamic force distribution is to optimum generate suitable force commands (F_{xi}^*) for the next force controls when there are redundant actuators.

By the traction force control of the tires, the required driving force (F_{ac}^{**}) and yaw moment (M_{zx}^{**}) are realized.

Force distribution is also a constrained optimal problem. When F_{ac}^{**} and M_{zx}^{**} are given, the “optimal distribution” should be subjected to the following constraints:

$$F_{ac}^{**} = F_{x1}^* + F_{x2}^* + F_{x3}^* + F_{x4}^* \quad (18)$$

This equation means the sum of the force commands should be equal to the required total accelerating force to meet driver’s traction or braking command.

$$M_{zx}^{**} = d_f(F_{x2}^* - F_{x1}^*) + d_r(F_{x4}^* - F_{x3}^*) \quad (19)$$

This equation means yaw moment calculated from force commands should be equal to the required yaw moment calculated by higher controller.

$$F_{xi}^{*2} \leq \hat{\mu}_{max}^2 \hat{F}_{zi}^2 - F_{yi}^2; i \in \{1,2,3,4\} \quad (20)$$

Those inequality equations mean that the generated force commands should be less than the maximum friction forces and kept in the safety domains.

There are two redundant variables. Hence it is impossible to get unique solutions. However, it is that redundancy makes it possible to optimize some other criterions. For example, the tire work load can be minimized by actively controlling redundant actuators.

Considering the above mathematic descriptions, the force distribution problem can be stated as:

Cost function

$$J(F_{xi}^*) \rightarrow \min$$

Subject to

$$(1) F_{ac}^{**} = F_{x1}^* + F_{x2}^* + F_{x3}^* + F_{x4}^*$$

$$(2) M_{zx}^{**} = d_f(F_{x2}^* - F_{x1}^*) + d_r(F_{x4}^* - F_{x3}^*)$$

$$(3) F_{xi}^{*2} \leq \hat{\mu}_{max}^2 \hat{F}_{zi}^2 - F_{yi}^2; i \in \{1,2,3,4\}$$

4.2 Dynamic Force Distribution Using Constrained Quadratic Programming

4.2.1 Cost Function

Considering the tire friction conditions, which are shown in Fig.3, we define tire work load as:

$$\rho = \sqrt{\frac{F_x^2 + F_y^2}{F_z^2}}$$

We define the cost function as:

$$J = \|\rho\|_2^2 \quad (21)$$

where $\rho = (\rho_1 \ \rho_2 \ \rho_3 \ \rho_4)^T$ is a vector of tire work load. The problem of dynamic force distribution becomes:

$$J = \|\rho\|_2^2 = \sum_{i=1}^4 \frac{F_{xi}^2 + \hat{F}_{yi}^2}{\hat{F}_{zi}^2} \quad (22)$$

subject to Eq.18, Eq.19, and Eq.20.

4.2.2 Solutions

In the Eq.22, the lateral and normal forces are estimated on-line. The resolutions of the optimization are the resolutions of the dynamic force distribution.

There are many algorithms for solving the

constrained quadratic programming problem [3]. We in this paper do not prepare to talk about these mathematic theorem and numerical algorithms in details.

What we should mention is that there are two efficient methods for solving constrained quadratic programming problem till nowadays. One is the “Active set method” and the other is “Interior-point method”. In this study we use the “Active set method”, which has the less computation load and high accuracy in the small dimensional case.

5. EVALUATION BY EXPERIMENTS

5.1 Active Yaw Moment Control with Dynamic Force Distribution

The main goal of active yaw moment control is to improve maneuverability or maintain stability in critical driving situations. In those cases, it is difficult for drivers to control the EV freely. At that time, control system is expected to work as a drive assistant.

However, the required yaw moment or total force cannot be a direct input command for the force control of tire. In this paper active yaw moment control is implemented with dynamic force distribution. It is used to generate force commands for force control by optimally managing redundant driving motors. Fig.7 shows the block diagram of whole control system.

In the integrated control system, yaw moment control is the high level controller. It calculated the active yaw moment which is required for yaw rate control. This yaw moment controller integrates yaw rate feed back control with yaw moment feed forward control.

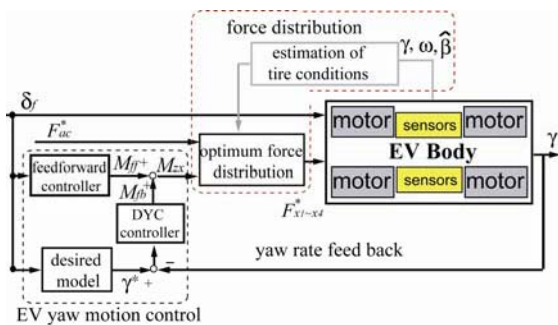

Fig. 7 Block diagram of integrated control system

5.2 Experiment and Evaluations

5.2.1 Experiment

The design of experiment is shown in Fig.8. The EV is controlled to turn a constant radius circle on a slipping road. The turning radius is about 15 meters. The initial velocity is about 10 km/h. The friction coefficient is about 0.3~0.4. During experiment, the steering angle is kept as a constant value. The driving force is also kept constant.

In this experiment, the EV is controlled to follow a desired behavior, which is the neutral steering

characteristic. In this experiment, we try to realize that neutral steer performance by controlling yaw rate of EV.

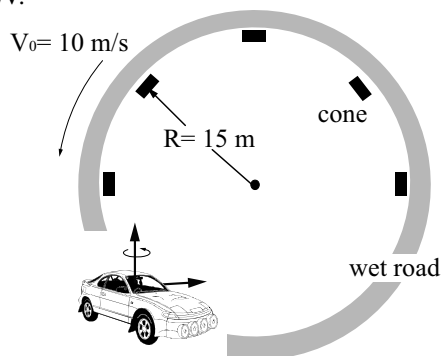

Fig. 8 Expression of the experiment

5.2.2 Evaluations

Using that experiment, we evaluate our proposed dynamic force distribution method by comparing the equal distribution method, which distribute the left and right forces in an equal way.

Without any control method, as Fig.9 shows, EV can not follow the desired neutral steering. The error between the reference yaw rate and the real one becomes larger and larger.

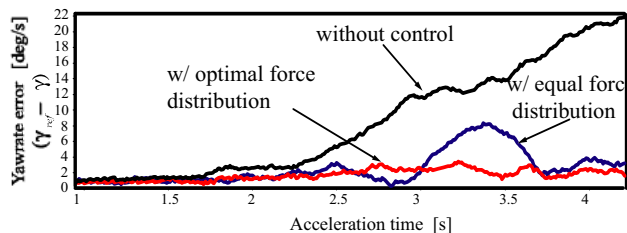

Fig. 9 Description of the experiment

The turning radius is 15 meters; steering angle is 200 degree; acceleration torque of four motors is about 1036 Nm, the longitudinal acceleration is about 0.1g

Fig. 9 also shows that the proposed force distribution method can improve the turning performance much better than what of the equal distribution method does.

Fig.10 shows the corresponding force commands which are generated by the dynamic force distribution for the driving motors.

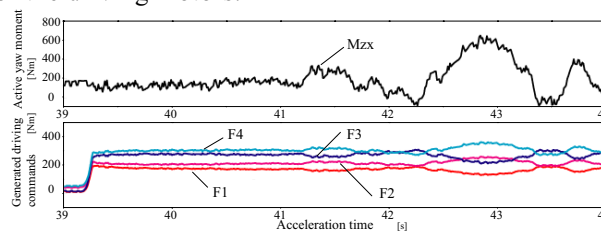

Fig. 10 Time history of the controlled driving torque (according to the generated active yaw moment)

Further, it is well known that the lateral acceleration of the EV is also important for the handling characteristic of the EV. We also discuss the effect of proposed control method on the lateral acceleration of EV. We compare the equal force distribution method

with the proposed method. The effect of proposed dynamic force distribution on the lateral acceleration is shown in Fig.11.

The experiment results indicate that the maximum lateral acceleration is enlarged by the proposed method. However, in the case of equal force distribution, the effect on the lateral acceleration of EV is not so much as the proposed method.

From the results mentioned above, it can be shown that the dynamic optimum force distribution improves the handling characteristics of EV.

Besides that we also try different control methods, which act as the outer-loop yaw rate controller. A 2-DOF controller is designed and integrated with the proposed dynamic force distribution method. Experiment results also show a quite well corporation of proposed force distribution with the higher level control law.

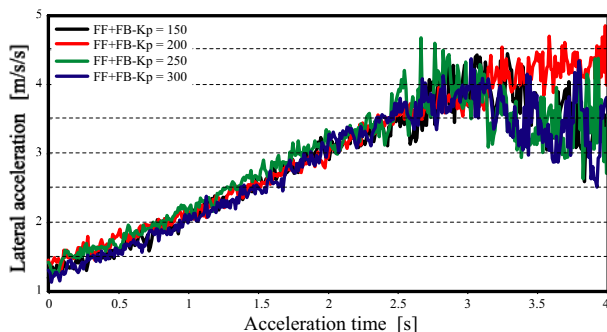

Fig. 11 Description of the experiment

The turning radius is 15 meters; steering angle is 200 degree; acceleration torque of four motors is about 932 Nm, the longitudinal acceleration is about 0.13g; the gains are changed.

6. CONCLUSIONS AND FUTURE WORKS

In this paper, we discuss the dynamic force distribution for motion control of multi-wheel-driven EVs. We evaluate that method by the experiments. The results show that the method can greatly improve the handling dynamics of that kind of EV, especially when it derives in a dangerous condition.

We also discuss the technologies about dynamic force distribution in this paper. For example, the yaw rate control logic and tire force observation.

In the future, the estimation of tire working conditions should be improved. For example, the lateral friction force can be known easily and accurately. Based on the obtained information of tire forces, the dynamic optimum force distribution method will be realized on-line more easily.

ACKNOWLEDGEMENT

We would like to thank Mr. Hiroaki Yoshida, Mr. Makoto Kamachi and their colleagues of MITSUBISHI MOTORS for cooperation of the experiments and many helpful discussions on this work.

REFERENCES

- [1] Yoichi Hori: "Future vehicle driven by electricity and control research on 4 wheel motored 'UOT March II'", IEEE Transactions on Industrial Electronics, Vol. 51, No. 5, pp. 954-962, 2004.10.
- [2] Shin Ichiro Sakai, Hideo Sado and Yoichi Hori: "Motion control in an electric vehicle with 4 independently driven in-wheel motors", IEEE Trans. on Mechatronics, Vol. 4, No. 1, pp. 9-16, 1999.
- [3] Peng He, Yoichi Hori: "Resolving actuator redundancy for 4WD electric vehicle by sequential quadratic optimum method", the 19th Japan Industry Applications Society Conference, Fukui, Japan, 2005.8.
- [4] Peng He, Yoichi Hori, Makoto Kamachi, Kevin Walters, and Hiroaki Yoshida: "Future motion control to be realized by in-wheel motored electric vehicle", the 31st Annual Conference of the IEEE Industrial Electronics Society, Raleigh, North Carolina, USA, 2005. 11.
- [5] Hiroshi Fujimoto, Akio Tsumasaka, and Toshihiko Noguchi: "Direct yaw moment control of electric vehicle based on cornering stiffness estimation", the 31st Annual Conference of the IEEE Industrial Electronics, Society, Raleigh, North Carolina, USA, 2005. 11.
- [6] Hideo Sado, Shin Ichiro Sakai, and Yoichi Hori: "Road condition estimation for traction control in electric vehicle", the 1999 IEEE international symposium on industrial electrics, bled. Slovenia, TH8465, Vol.2, pp.973-978, 1999.
- [7] Yoshifumi Aoki, Tomoko Inoue, and Yoichi Hori: "Robust design of gain matrix of body slip angle observer for electric vehicle and its experimental demonstration", Proceeding of AMC2004, 2004.
- [8] Ono E., Hattori Y., Muragishi Y., and Koibuchi K. : "Vehicle dynamics integrated control for four wheel distributed steering and four wheel distribution traction/braking system", vehicle system dynamics, Vol.44, No.2, pp. 139-151, 2006, 2.

BIOGRAPHIES

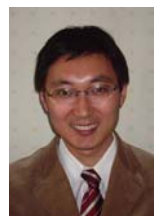

Peng He received M.S. degree in 2001. He is a Ph.D candidate of the University of Tokyo. He is interested in the researches about robust control, redundancy and optimal control. Now he studies the advanced motion control of electric vehicle.



Yoichi Hori received Ph.D degrees in Electrical Engineering from the University of Tokyo in 1983 and joined the Department of Electrical Engineering as a Research Associate. He later became a Professor in 2000. In 2002, he moved to the Institute of Industrial Science as a Professor of Information & Electronics Division. His research fields are control theory and its industrial application to motion control, mechatronics, robotics, electric vehicle, etc. He worked as Treasurer of IEEE Japan Council and Tokyo Section during 2001-2002. He is now an AdCom member of IEEE-IES. He was the Vice President of IEE-Japan IAS in 2004-2005. He has been the chairman of ECaSS Forum since 2005. He is the program chairperson of EVS-22. He is IEEE Fellow.