

Article

Enhanced Energy Distribution for Quantum Information Heat Engines

Jose M. Diaz de la Cruz ^{1,*} and Miguel Angel Martin-Delgado ²

¹ Department of Applied Physics and Materials Engineering, Universidad Politecnica de Madrid, 28006 Madrid, Spain

² Department of Theoretical Physics, Universidad Complutense de Madrid, 28040 Madrid, Spain; mardel@fis.ucm.es

* Correspondence: jose.diazdelacruz@upm.es; Tel.: +34-913-36-31-00

Academic Editor: Jay Lawrence

Received: 5 August 2016; Accepted: 12 September 2016; Published: 14 September 2016

Abstract: A new scenario for energy distribution, security and shareability is presented that assumes the availability of quantum information heat engines and a thermal bath. It is based on the convertibility between entropy and work in the presence of a thermal reservoir. Our approach to the informational content of physical systems that are distributed between users is complementary to the conventional perspective of quantum communication. The latter places the value on the unpredictable content of the transmitted quantum states, while our interest focuses on their certainty. Some well-known results in quantum communication are reused in this context. Particularly, we describe a way to securely distribute quantum states to be used for unlocking energy from thermal sources. We also consider some multi-partite entangled and classically correlated states for a collaborative multi-user sharing of work extraction possibilities. In addition, the relation between the communication and work extraction capabilities is analyzed and written as an equation.

Keywords: quantum information heat engines; entanglement entropy; quantum cryptography; quantum thermodynamics

1. Introduction

The study of the relation between computational irreversibility and energy can be traced back as far as 1961 when Landauer [1] established that irreversible steps in a computation should dissipate an amount of heat directly related to the loss of information (an experimental demonstration thereof has been published in 2012 [2]). On this line followed another important contribution by Bennett [3]. He claimed that any computation can be made reversible by the allocation of information in more registers (now known as ancillas), which can be deleted by the end of the process. Hamiltonian evolutions are reversible, and, if they are time independent, do not dissipate any energy so that, under these circumstances, reversibility is directly related to energy conservation. Using quantum mechanics, in Feynman [4], Benioff [5] and Deutsch [6] proposed models for quantum computers with Hamiltonian evolutions that minimized energy losses. A fairly up-to-date review of information and quantum computation can be found in [7], and a comprehensive textbook in [8].

Another fruitful relation between energy and information began in the *Theory of Heat* published by Maxwell [9] in 1871; he suggested that the introduction of an imaginary demon in a gas chamber could extract work from a single temperature gas volume. A further important contribution along this line is the Szilard's Engine [10] and countless studies later on paradoxes, contradictions or refinements of the said law. A lot of papers in the last years have elucidated the question from different perspectives, all of them confirming the validity of the second principle of thermodynamics [11–14].

Szilard engines and Maxwell demons analysis are often prone to misunderstandings. In our view, they could be avoided with careful accounting for information and energy trade-off in the presence of feed-back systems [14,15]. Generally, they use a *controller*, which is governed by a number of bits (qubits in quantum environments). These bits are stored in some information container or *memory*. To change these bits, it is necessary to reset them, and thus some of Landauer's work must be brought in and some entropy poured somewhere else. Then, they must be replaced by new information coming from a *measurement* on the system, whereby some entropy is taken away. After that, some work can be obtained from the freshly measured bits. The process is then neutral in information and energy, unless entropy and work can be taken away in exchange of information. We would like to emphasize that the real fuel for these devices is information, as is explained in [16] for a magnetic quantum information heat engine, which is a new version of Szilard's engine devoid of some irrelevant details. An alternative to the measuring stage is periodically swapping high-entropy states in the engine with low-entropy ones supplied by feeding ancillas [16,17].

It is now well understood that the availability of a thermal bath allows for a trade-off between information and work. The devices that carry out this conversion are known as *Information Heat Engines* [12,13,16,18–30]. The information may be classical or quantum and the available energy could differ in both cases. The difference is defined by the *work deficit* [31] or *quantum discord* [32–34]. In addition, the extractable work can be related to the relative entropy or Kullback–Leibler divergence [35–38]. Quantum statistical considerations with fermionic and bosonic multiparticle systems have also been analyzed elsewhere [13,16,25,29,39–42].

Other magnetic machines (classical and quantum) have been proposed for other different thermodynamic cycles, especially cooling systems [29,43–45].

The role of standard entropy in Information Heat Engines is relevant for average values of extracted work. Generalizations to the so called *smooth* entropies have been made to include other fluctuations and probabilities of failure [46–48]. This perspective is not considered in the present paper.

In this contribution, a new scenario for communication and energy distribution is defined that allows the consideration of novel possibilities concerning the security and conditions of use for both the information and energy convertibility stored in a shared quantum state.

Quantum information resources for communication have already been adapted to energy distribution [49,50] and described using Ising chains [51]. They differ from our approach basically because they use an entangled vacuum state for a non-local Hamiltonian that has to be shared by both the energy provider and consumer. On the other hand, our proposal includes the use of Quantum Information Heat Engines (henceforth QIHE) and the availability of a thermal bath at non-zero temperature.

In Section 2, we provide a short description of a basic model for a QIHE, to which further ideas will be referred throughout the rest of the paper. Section 3 analyzes the transmission of physical systems, that will be referred to as *messengers*, whose entropy may be increased at a remote station in order to extract work from thermal baths; several protocols with different functionalities are presented. For example, by using shared entangled states, qubits sent from an emitter *A* to a receiver *B* are completely depolarized (in this work, a completely depolarized system is equivalent to a system with maximum entropy. Taking into account that Information Heat Engines extract work by increasing the entropy of the fueling system, a completely depolarized state yields zero work), and thus useless for any illegitimate user that could intercept them; other multipartite systems render other interesting possibilities concerning the conditions to access not completely depolarized systems. Sections 4 and 5 analyze the transmission of physical systems in a given quantum state from two different perspectives that prove to be complementary. One of them is quantum communication, where new milestones [52,53] are frequently announced, and the other is the possibility to fuel a QIHE under suitable restrictions. A relationship between the communication and work extraction capabilities of sources of physical systems is sought and an equation is found. Section 5 specifically focuses on proving the possibility of reaching the Holevo bound for communication performance and simultaneously

using the messenger system to fuel a QIHE, whereas in Section 4, both functions are supposed to be used exclusively. Section 6 summarizes the conclusions.

2. Short Description of a Quantum Information Heat Engine

Information Heat Engines are devices that cyclically convert thermal energy into useful work at the expense of degrading information. They are periodically fueled with auxiliary systems, whose entropy is increased, although their energy is conserved. The power delivered by the engine is drawn from a single thermal reservoir. This is in contrast with other cyclic engines that decrease the internal energy of the systems that are supplied as fuel. It should also be remarked that they comply with all three principles of thermodynamics. In the following, we assume that the engine is a physical system with a local Hamiltonian and no energy is exchanged with the fueling system. If the evolution is divided into intervals with either Hamiltonian evolution or reversible thermal equilibrium with a bath at temperature T , the work after a complete cycle can be evaluated by

$$W_{\text{cycle}} = - \oint_{\text{cycle}} d(\text{Tr} \{ \rho H \}) + \int_{\text{te}} k_B (\ln 2) T dS, \quad (1)$$

where the first integral extends for the whole cycle and vanishes on account of its periodic domain. The second integral is defined only for the intervals when the system is at thermal equilibrium with the bath. In addition, entropy is expressed in bits; k_B is Boltzmann's constant, ρ is the density matrix of the system and H represents the Hamiltonian. The result is

$$W_{\text{cycle}} = k_B (\ln 2) T \Delta S, \quad (2)$$

which shows that work can be obtained only if entropy is reset to a lower value at some point in the cycle. Entropy extraction can be accomplished in a number of ways. The simplest one is swapping the quantum state of the system with that of an ancilla with an initially lower value of entropy. More frequently, entropy is extracted through feedback control. In this case, the system is driven to a lower entropy state by first measuring and then triggering the suitable Hamiltonian to make the system evolve to the desired state. As it is thoroughly analyzed in [16], a measurement involves two systems: the measurand and the indicator, which must start in a well-defined state. After the measurement, the indicator ends up with some entropy, on account of the unpredictability of the outcome. In contrast, the system is brought to a less entropic state by virtue of the tailored Hamiltonian evolution triggered according to the outcome of the measurement. It is after the measuring stage that entropy has to be removed by resetting the indicator; the Landauer's work is precisely the product of this entropy and the temperature. We assume that the states of the indicator have negligible energy differences in order to isolate its purely informational role.

In a single particle cylinder Szilard engine, as shown in Figure 1, measurement of which side is performed and isothermal expansion against a wall in the suitable direction follows. A barrier is then repositioned at the middle of the cylinder. The entropy increase between the moment following the measurement and immediately after the reinsertion of the barrier is exactly one bit, corresponding to the loss of information about which side of the cylinder the particle is in. Correspondingly, the extracted work per cycle $W_{\text{cycle}}^{\text{Sz}}$ is

$$W_{\text{cycle}}^{\text{Sz}} = k_B (\ln 2) T. \quad (3)$$

In a magnetic quantum information heat engine [16], as shown in Figure 2, measurement of the z -component of the magnetic moment of a spin- $\frac{1}{2}$ particle is followed by the onset of a suitable magnetic field, which is later gradually removed in a stage at thermal equilibrium with a thermal reservoir. Exactly as in the one particle Szilard cylinder, the entropy increase between the moment after the measurement and the restart of the process is one bit and Equation (3) holds.

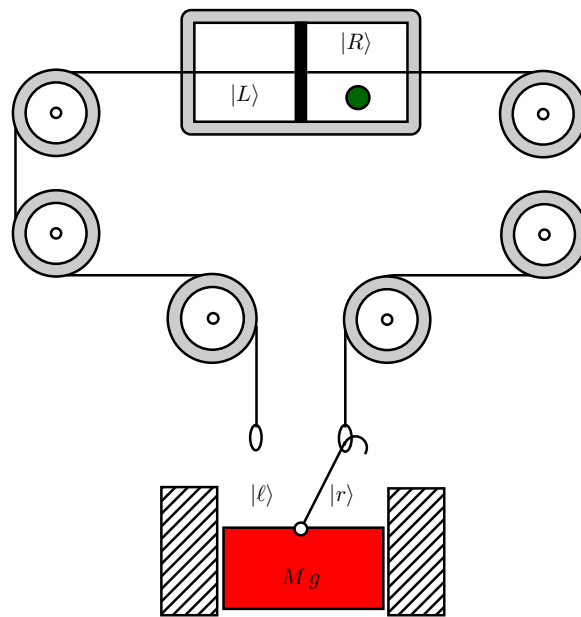

Figure 1. One particle Szilard cylinder engine; a measurement is carried out to determine whether the particle is in the $|L\rangle$ or $|R\rangle$ state and the result is stored in the $|\ell\rangle$ or $|r\rangle$ state of an indicator which, in turn, determines whether the mechanical plunger is attached to the left or right end of the cable depicted in the figure. The work stored in the potential energy of the plunger after full expansion of the barrier in the cylinder is $k_B (\ln 2) T$, and is exactly equal to the Landauer’s work that would be needed to reset the indicator before the beginning of the next cycle. If the system works as a QIHE, instead of this energy, a fresh entropy-free indicator bit is supplied.

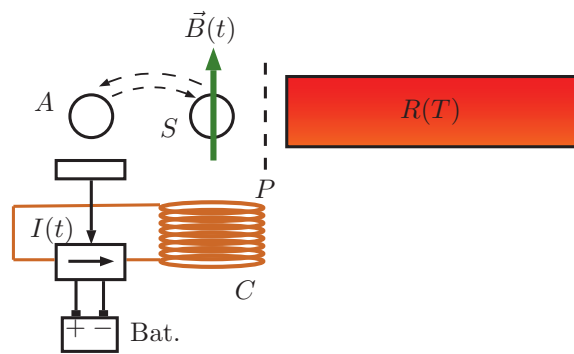

Figure 2. Magnetic Quantum Information Heat Engine; a spin- $\frac{1}{2}$ particle S lies in the magnetic field generated by an electrical current $I(t)$ circulating through a coil C . An ancilla A is used to measure the z component of the magnetic moment of S ; the result determines the value of the magnetic field generated by $I(t)$. Then, the field is gradually turned off, while S keeps in thermal equilibrium with a reservoir $R(T)$ at temperature T . At the end of the process, an energy W is stored at the electrical battery B ; its value is $W = k_B (\ln 2) T$, on account of the increase of entropy of S , which enters the isothermal process with zero entropy and exits completely depolarized. Again, this energy is equal to the Landauer’s energy needed to reset the ancilla for the next cycle. If the system works as a QIHE, instead of this energy, a fresh entropy-free ancilla bit is supplied.

The resource theory behind energy extraction [37,54–56] establishes that the obtainable work is related to the free energy of the state that describes the ancilla; when the energy differences are negligible, the important magnitude is the entropy. These results are generalized to develop a general formalism to calculate the maximum efficiency of work extraction from an arbitrary quantum system

in [57]. It is then straightforward to envisage a system for distribution of *purity*. Basic quantum cryptographic procedures can be implemented in order to lock it for all but a legitimate participant and render it useless for anyone else. Furthermore, we analyze the possibilities furnished by some particular entangled states to enforce a collaborative procedure for unlocking the *purity* of the ancilla state.

3. Scenario for Energy Distribution through Quantum Information in Multipartite Systems

In the previous sections, it has been established that a physical system whose quantum state is not completely depolarized can be transformed into another state with greater entropy and obtain work in the process, provided the availability of a thermal bath and an Information Heat Engine, like a Szilard or a magnetic information engine as described in Section 2.

Now, we set up a new scenario for energy distribution: a power information plant P can do the reverse process and polarize a *messenger* physical system M by supplying electrical (or mechanical or of any other kind) work (see Figure 3a). If the system M (a photon polarization, for instance) is sent to other users A, B, \dots (may be in remote places), they can do the reverse operation and obtain work by depolarizing the system, provided they know the state of M . Note that, if the reservoirs are at different temperatures, this is equivalent to a (remote) Carnot cycle (see Figure 3b).

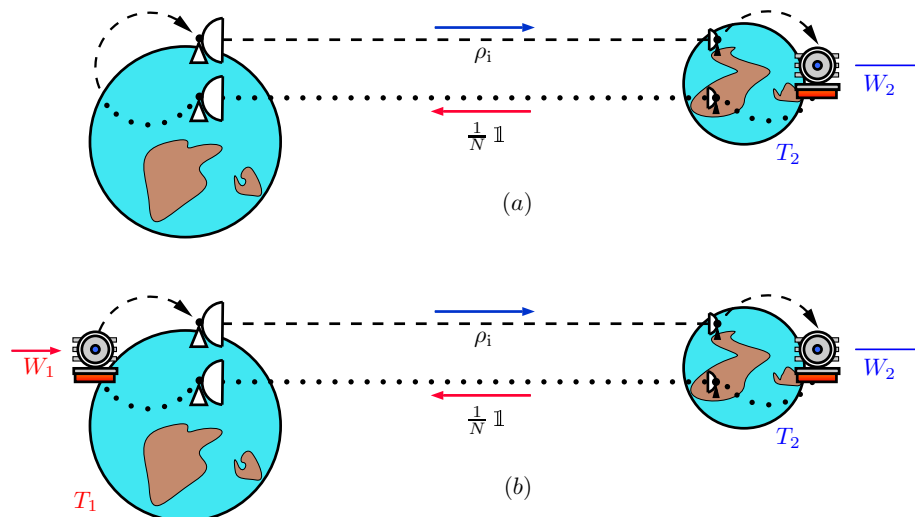

Figure 3. Part (a) represents a way of supplying energy to a remote station at temperature T_2 , consisting of sending physical systems in a quantum state ρ_i whose entropy increases after fueling a QIHE and return as completely unpolarized states. As an example, photons can be sent to the remote station under a particular polarization and return completely unpolarized. The extracted work is $W_2 = k_B (\ln 2) T_2$; In (b), a remote Carnot cycle is depicted, where entropy is interchanged between the primary station at temperature T_1 , where entropy is pumped out of the traveling physical system at a work cost $W_1 = k_B (\ln 2) T_1$, and the remote station. In this scenario, the net work gain per transmitted qubit is $W = W_2 - W_1 = k_B (\ln 2) (T_2 - T_1)$ and, taking into account that the heat taken from T_2 is $Q_2 = k_B (\ln 2) T_2$, it follows that $W = Q_2 (1 - \frac{T_1}{T_2})$, which is the standard result for Carnot cycles.

The next important issues about this scenario are the security and shareability. As a first scenario, one could send some messenger qubits from the power plant P to A , so that A can convert them into work. In order for A to be able to obtain energy from the qubits, A must know something about the state ρ of said qubits. If all the qubits were in the same state, this could be learned by someone else (eavesdropper E) who could use them to draw some work from an available thermal reservoir. One possible solution that would avoid this reward for E , as we know from quantum security communication protocols, is to share a set of entangled qubits; then, sending a qubit from P would make A obtain two fresh convertible bits (superdense coding). Thus, the same protocols that serve the

purpose of protecting information can be used to secure that no unauthorized user converts the qubits into work. In short, we can implement a cryptographic protocol that renders the S qubits completely unpolarized (useless) for any eavesdropper while carrying two convertible bits for legitimate users.

As an example, A and B may agree on sharing a set of Bell pairs. Let $|\Psi\rangle_{AB}$ be one of them. As it is widely known, the partial density matrices describing the A and B parts of $|\Psi\rangle_{AB}$ are completely depolarized, being:

$$\rho_A = \rho_B = \frac{1}{2} \begin{pmatrix} 1 & 0 \\ 0 & 1 \end{pmatrix}, \tag{4}$$

or, in other words, no information is available in the local subsystems. However, when A sends its qubit to B through a quantum channel, B can reconstruct the bipartite initial Bell state, which is a pure state and can be used to extract a work W_{BS} given by

$$W_{BS} = 2k_B (\ln 2) T_B. \tag{5}$$

It is important to note that interception of just the qubit being sent from A to B is useless for any illegitimate user, on account of its total depolarization; only the two qubits together can be fruitful. In addition, it should also be remarked that the whole entropy generated in resetting the Bell pair is extracted from the thermal bath at B , so that nothing is lost. As a further remark, if thermal baths at different temperatures T_A, T_B are used as sources or sinks of entropy in A, B , the system as a whole functions as a remote direct Carnot cycle if $T_A < T_B$ or a reverse one when $T_B > T_A$.

A classical version of this protocol can be devised where a set of completely correlated random bits would be used instead of the Bell states. However, completely correlated pairs of random bits carry one bit of entropy, and, consequently, the extractable work W_{CB} would be

$$W_{BS} = k_B (\ln 2) T_B, \tag{6}$$

which is only half of the one given by Equation (5). This reduction can be related to the superdense coding feature of quantum communication, i.e., one qubit may be used to communicate two classical bits.

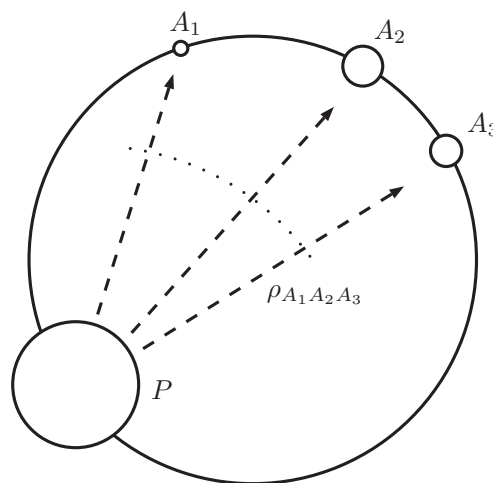

Figure 4. The source P sends $\rho_{A_1 A_2 A_3}$ states to remote systems A_1, A_2, A_3 .

There are further possibilities: one can use multipartite states ρ_{A_1, \dots, A_n} (see Figure 4) that allow energy extraction under one of the following two situations:

- (i) any user A_i can independently make that the other ones ($A_{j \neq i}$) access the energy of one bit in their part of ρ_{A_1, \dots, A_n} . This possibility can be implemented by using generalized

Greenberger–Horne–Zeilinger (GHZ) states, also known as cat states. An n -partite GHZ state is a pure state:

$$|\text{GHZ}_n\rangle := 2^{-1/2} \left(|0\rangle^{\otimes n} + |1\rangle^{\otimes n} \right), \tag{7}$$

with two remarkable properties: (1) any local measurement destroys the entanglement and (2) the partial states are completely unpolarized (useless for energy conversion). User A_i can measure its qubit and then classically broadcast the result to all other users who can subsequently convert their $n - 1$ bits into work.

- (ii) only if all users agree, one of them can convert the energy. For this purpose, we may use a classically correlated mixed state:

$$\rho_{EP} := \frac{1}{2^n} \sum_{i_1, \dots, i_n} (1 + (-1)^{i_1 + \dots + i_n}) \sigma_{i_1, \dots, i_n}, \tag{8}$$

where i_k may be 0 or 1 and, for notational simplicity, we define

$$\sigma_{i_1, \dots, i_n} := |i_1, \dots, i_n\rangle \langle i_1, \dots, i_n|. \tag{9}$$

According to Equation (8), ρ_{EP} is a mixture of all even parity pure states. It can only furnish one bit of information upon knowing all but one bits measured on the standard basis. We will now prove this. For that purpose, we will show that any operation on $n - 2$ qubits, say $3, \dots, n$, gives no information about qubit 1. Let K_j be the Krauss operators; then, ignoring a possible normalization factor, the state of the system after it is:

$$\rho' = \sum_j K_j \rho_{EP} K_j^\dagger, \tag{10}$$

where $K_j := \mathbb{1}_2 \otimes \mathbb{1}_2 \otimes k_j$, what accounts for the fact that the operation is on the last $n - 2$ qubits. Expanding ρ_{EP} , we have

$$\rho' = \sum_j \sum_{i_3, \dots, i_n \in E} k_j \sigma_{i_3, \dots, i_n} k_j^\dagger \otimes \sigma_{i_1, i_2}. \tag{11}$$

Next, we separate the $i_3, \dots, i_n \in E$ (set of even parity $n - 2$ -tuples of bits) and $i_3, \dots, i_n \in O$ (set of odd parity $n - 2$ -tuples of bits) contributions so that

$$\begin{aligned} \rho' = & \sum_{i_3, \dots, i_n \in E, j} k_j \sigma_{i_3, \dots, i_n} k_j^\dagger \otimes (\sigma_{0,0} + \sigma_{1,1}) \\ & + \sum_{i_3, \dots, i_n \in O, j} k_j \sigma_{i_3, \dots, i_n} k_j^\dagger \otimes (\sigma_{0,1} + \sigma_{1,0}). \end{aligned}$$

Subsequently, we trace over all but the first and second qubits to obtain ρ'_{12} ; let the constants C_E, C_O be defined by:

$$C_{E/O} := \sum_{\substack{i_3, \dots, i_n \in E/O, j \\ \ell_3, \dots, \ell_n}} |\langle \ell_3, \dots, \ell_n | k_j | i_3, \dots, i_n \rangle|^2, \tag{12}$$

so that the partial trace results

$$\rho'_{12} = C_E(\sigma_{0,0} + \sigma_{1,1}) + C_O(\sigma_{0,1} + \sigma_{1,0}), \tag{13}$$

and, finally, tracing over the second qubit, we obtain:

$$\rho'_1 = C_E(\sigma_0 + \sigma_1) + C_O(\sigma_1 + \sigma_0) = (C_E + C_O) \mathbb{1}_1, \tag{14}$$

which shows that no information is gained about qubit 1, as it had been previously anticipated.

4. Mutual Limitation between Communication and Energy Extraction

According to the previous paragraphs, posting messenger quantum states from P to A may serve one or two of the following purposes: sending qubits to be converted into energy and communicating information. Both features are mutually exclusive functions whose limiting relation is next obtained.

Holevo [58] in 1998, and Schumacher et al. [59] in 1997, established that, given an alphabet consisting of (1) a set of \mathcal{N} quantum mixed states (also known as letters) described by their density matrices $\{\rho_a, a = 1 \text{ through } \mathcal{N}\}$, and (2) a set of probabilities $\{p_a, a = 1 \text{ through } \mathcal{N}\}$, according to which the states have to be used, one can devise a communication protocol to convey χ bits (in average for sufficiently long messages) of classical information per state in the alphabet, where χ is defined as the *Holevo information* of the alphabet:

$$\chi := S(\rho_B) - \langle S_a \rangle, \tag{15}$$

where

$$\rho_B := \sum_{a=1}^{\mathcal{N}} p_a \rho_a \tag{16}$$

is the mixed state that exits the emitter A according to the information of the receiver B and

$$\langle S_a \rangle := \sum_{a=1}^{\mathcal{N}} p_a S(\rho_a). \tag{17}$$

It is understood that the communication protocol assigns a sequence of states in the alphabet, or a *codeword*, to every message that can be transmitted.

We are now going to use this theorem [60] to state a new interesting result.

Let us now describe a bipartite scenario, with A (Alice) and B (Bob). A messenger physical system M can be emitted from A to B . The states of M belong to a finite set $\rho \in \{\rho_B, \dots, \rho_{\mathcal{N}}\}$. In addition, the availability of the states of M follows a probability distribution $\{p_1, \dots, p_{\mathcal{N}}\}$ that determines the frequencies with which the states of M have to be used. Thus, the states $\{\rho_a, a = 1 \text{ through } \mathcal{N}\}$ with probabilities $\{p_a, a = 1 \text{ through } \mathcal{N}\}$ make the letters of an alphabet. If Alice and Bob agree on a certain code, the ordering of the states sent from A to B may be used to communicate messages, according to the Holevo information of the alphabet. In addition, not completely depolarized systems can also be used to fuel a QIHE, provided that there is a thermal bath at B .

According to Equation (2), the average work (\mathcal{E}) obtainable from each letter reads

$$\mathcal{E} = k_B T (\ln 2) (\mathcal{M} - S(\rho_B)), \tag{18}$$

where

$$\mathcal{M} := \log_2 d, \tag{19}$$

and d is the dimension of the Hilbert space for the physical system M ; \mathcal{M} is then the equivalent number of qubits per letter in the alphabet (note that \mathcal{M} is not generally an integer number). Accordingly, substituting for $S(\rho)$ in Equation (15) yields

$$\frac{\mathcal{E}}{k_B T \ln 2} + \mathcal{C} + \langle S_a \rangle = \mathcal{M}, \tag{20}$$

where \mathcal{C} is the average information per emitted letter that one can communicate using the alphabet $\{\rho_a, p_a\}$, which, according to the previous paragraph, is equal to χ . Equation (20) states the mutual limitation between communication and energy as is graphically represented in Figure 5.

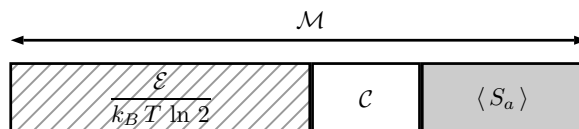

Figure 5. When some source of quantum states is used to convey classical information, it may also serve as an ancilla to extract work from a thermal source. Equation (20) sets a mutual limitation for both functions. This figure represents a distribution of the functionality of a source $\{\rho_a, p_a\}$ per transmitted letter between energy conversion \mathcal{E} (hatched), communication C (white) and a useless part $\langle S_a \rangle$ (gray), showing that they add up to M .

5. Simultaneous Supply of Information and Work Extraction Capability

The derivation of Equation (20) in the previous section was based on independent results for communication and thermodynamics scenarios. It proves that there is a relation between two different functions of the states of a system M , when they are used exclusively, which is for either sending messages or fueling a QIHE. Next, we show that both functions can be obtained simultaneously for the same system with a mutual limitation of Equation (20). For that, we refer to the decoding of information described in [59]. Briefly stated, the results put forward in that paper which are relevant to this work are:

Given any positive real numbers ϵ, δ and a set of states of a physical system M with Hilbert space \mathcal{H} , $\{\rho_a, a = 1$ through $\mathcal{N}\}$ with probabilities $\{p_a, a = 1$ through $\mathcal{N}\}$; then, for a sufficiently large integer L :

1. there is a typical subspace $\Lambda_{L,\epsilon,\delta} \subset \mathcal{H}^{\otimes L}$, whose orthogonal projector is $\Pi_{L,\epsilon,\delta}$ that verifies

$$\text{Tr} \{ \Pi_{L,\epsilon,\delta} \rho_L \} > 1 - \epsilon, \tag{21}$$

where $\rho_L := \rho_B^{\otimes L}$, and

$$\rho_B := \sum_{a=1}^{\mathcal{N}} p_a \rho_a; \tag{22}$$

in the following, we drop the subscripts L, ϵ, δ and simply write Λ to denote the subspace $\Lambda_{L,\epsilon,\delta}$;

2. the dimension d_Λ of Λ is bounded by

$$d_\Lambda := \dim(\Lambda) \leq 2^{L(\delta+S(\rho_B))}; \tag{23}$$

3. there is a communication protocol between Alice and Bob, whose information is coded (in [59], the codes are constructed by choosing a number of codewords independently, according to the a priori string probability for each codeword. The choice is supposed to be random and the results concerning the probability of error are averaged over the different possibilities) in the order in which Alice arranges the letters ρ_a before sending them to Bob, where the frequency of letter ρ_a is p_a , that achieves $\chi - 5\delta$ bits per letter with a probability of error $P_E \leq 10\epsilon$. When Bob receives the codewords sent by Alice, he performs a positive-operator valued measure (POVM) (positive-operator measure (POM) in the reference article [59]), defined by a collection of effects $E_j = |\mu_j\rangle \langle \mu_j|$, where all of the kets $|\mu_j\rangle$ belong to the typical subspace Λ . All the ensuing process of decoding relays only on the result of this POVM.

Our next purpose is to use this result to closely factorize the state $\rho_L = \rho_B^{\otimes L}$ into two parts: one which carries the information (and consequently should contain most of the entropy) and other which can fuel a QIHE (which, inversely, should have low entropy). As a first attempt, we would want to factorize the $d_L := 2^{LM}$ -dimensional Hilbert space into a d_Λ -dimensional one and another which

should accordingly have dimension d_L/d_Λ . This can only happen when d_L/d_Λ is a positive integer number, which is not the case in a general situation.

In order to guarantee the possibility of factorization in the general case, we enlarge the Hilbert space $\mathcal{H}_L := \mathcal{H}^{\otimes L}$ by a tensor product with a d_Λ -dimensional ancillary physical system D upon reception of the codeword by B . Let $|0\rangle_D$ be the initial state of the ancillary system D and denote by \mathcal{H}_D the Hilbert space of D .

The enlarged codewords live now in the $d_L \times d_\Lambda$ -dimensional space defined by the tensor product $\mathcal{H}_L \otimes \mathcal{H}_D$.

Next, we define the enlarged typical subspace $\Gamma := \Lambda \otimes 0^{d_\Lambda}$, where 0^{d_Λ} is the one-dimensional subspace of \mathcal{H}_D spanned by $|0\rangle_D$.

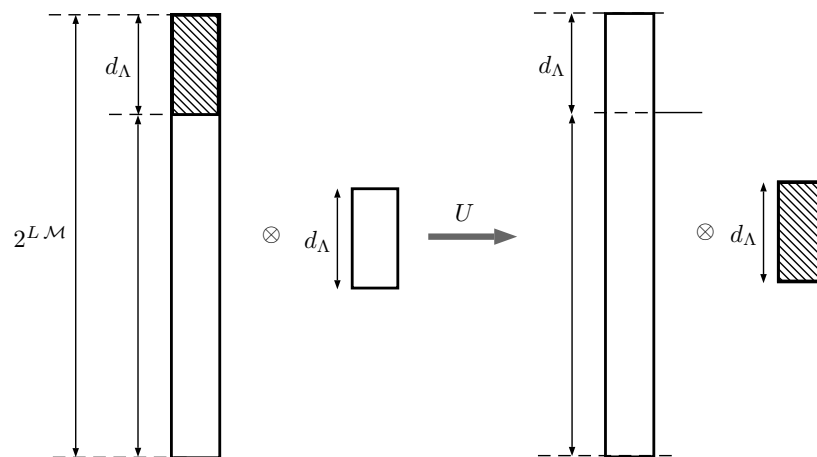

Figure 6. Pictorial view of the intuitive idea behind the refactorization process described in the main text. A codeword is a sequence of L letters and, accordingly, is an element of a 2^{LM} -dimensional Hilbert space \mathcal{H}_L . Codewords are not evenly distributed in \mathcal{H}_L , but are concentrated in a typical subspace Λ of dimension d_Λ . After enlarging \mathcal{H}_L by a tensor product of the codewords with a pure state $|0\rangle_D$ of an ancillary d_Λ -dimensional system D , we have a bigger system whose states are still concentrated in a d_Λ -dimensional subspace. A unitary transformation can always be found to map this subspace into the subspace defined by the tensor product of a pure state $|0\rangle_L \in \mathcal{H}_L$ and \mathcal{H}_D . This space is factorizable; the first part is fed into a QIHE and the second part undergoes the decoding process to extract the information sent from the emitter.

As the next step, we define a unitary transformation U which maps the enlarged typical subspace Γ into the subspace $|0\rangle_L \otimes \mathcal{H}_D$, where $|0\rangle_L$ is a pure state of \mathcal{H}_L . As both subspaces have the same dimension, such a unitary transformation is guaranteed to exist. This completes the process of transferring codewords in Λ to D , as is depicted in Figure 6. The first part of the system is fed to a QIHE, which will yield a work

$$W_1 = k_B T (\ln 2) L \mathcal{M}, \tag{24}$$

with a probability $> 1 - \epsilon$, corresponding to the case that the \mathcal{H}_L part is in the $|0\rangle_L$ state or, equivalently, that the codeword is in Λ and such probability is given by Equation (21). If not, the work may be negative, but never less than $-W_1$. Accordingly, the average work obtained verifies

$$W \geq k_B T (\ln 2) L \mathcal{M} (1 - 2\epsilon), \tag{25}$$

from which we should subtract the one necessary to restore the ancillary system

$$W_D = k_B T (\ln 2) \log_2 d_\Lambda, \tag{26}$$

and taking into account Equation (23),

$$W_D \leq k_B T (\ln 2) (LS(\rho_B) + L\delta), \tag{27}$$

and, consequently, the average net work per letter gained by the QIHE at B verifies

$$W_{\text{letter}} \geq k_B T (\ln 2) (\mathcal{M}(1 - 2\epsilon) - S(\rho_B) - \delta). \tag{28}$$

We also know, from the theory of QIHE, and ultimately from the Second Principle of Thermodynamics, that

$$W_{\text{letter}} \leq k_B T (\ln 2) (\mathcal{M} - S(\rho_B)), \tag{29}$$

so that the average work extractable per letter, in the $L \rightarrow \infty$ asymptotic limit, reads

$$\mathcal{E} := W_{\text{letter}} = k_B T (\ln 2) (\mathcal{M} - S(\rho_B)), \tag{30}$$

and Equation (20) holds for the case of simultaneous QIHE and communication use of a source of quantum states. Figure 7 represents the process.

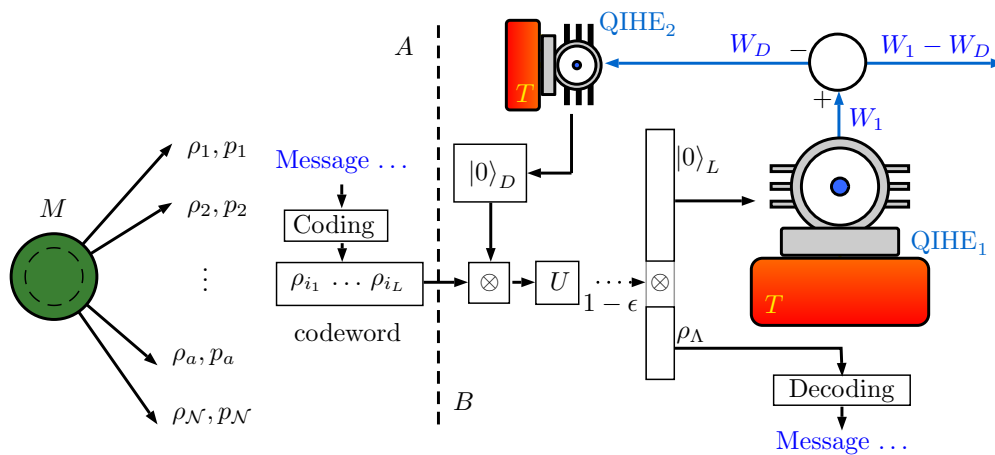

Figure 7. Schematic view of the process described in Section 5 for the simultaneous extraction of work and transmission of messages. There is a source of copies of a physical system M available to user A (Alice). Copies are in one of a predefined set of states ρ_a (letters), each with a probability p_a . Alice can arrange blocks of L copies in predefined *codewords*, which have been previously agreed with user B (Bob). The relative frequencies expected for each letter must follow the probability distribution. When the codeword reaches Bob, it undergoes a tensor product with a pure state $|0\rangle_D$ of an ancillary system D whose dimension is equal to that of the typical subspace Λ . The enlarged codeword then undergoes a unitary transformation U which, with at least $1 - \epsilon$ probability, factorizes it into two parts; one of them is a pure state $|0\rangle_L$ in a $2^{L\mathcal{M}}$ -dimensional space. The other factor is equivalent to the projection of the codeword on the typical space Λ , which can be further decoded to recover the original message. The state $|0\rangle_L$ can be fed to a QIHE (QIHE₁) to extract a work $W_1 = k_B T (\ln 2) \mathcal{M} L$. Part of it, $W_D = k_B T (\ln 2) \log_2 d_\Lambda$, has to be used to operate another QIHE (QIHE₂) acting reversely to generate a pure state $|0\rangle_D$ out of completely depolarized systems.

Given the set of states ρ_a of a system D , with probabilities p_a , as in the previous paragraphs, the last question to be discussed is whether Alice and Bob can arrange a protocol to increase \mathcal{E} and decrease \mathcal{C} or vice versa. The answer is that \mathcal{C} can not be increased over χ , on account of Holevo's theorem, but \mathcal{E} can be improved if Alice and Bob previously agree on decreasing \mathcal{C} .

A way to do it would be a previous agreement on always sending blocks of n copies of each letter. This is equivalent to replacing the alphabet of letters ρ_a with probabilities p_a by a new alphabet of letters $\rho'_a := \rho_a^{\otimes n}$ with the same probabilities p_a . In this case,

$$S(\rho'_a) = n S(\rho_a), C' \leq n C, M' = nM, \tag{31}$$

and thus,

$$\frac{\mathcal{E}'}{n} = M - \frac{C'}{n} - \langle S_a \rangle. \tag{32}$$

In the limit, $n \rightarrow \infty, \frac{C'}{n} \rightarrow 0$ and, consequently,

$$\frac{\mathcal{E}'}{n} \rightarrow M - \langle S_a \rangle. \tag{33}$$

This value can also be reached if Alice and Bob arrange a particular ordering of the states, declining to use them for communication. Figure 8 represents the simultaneous values per letter of (1) the extractable work \mathcal{E} and (2) communication bits \mathcal{C} that can be attained when Alice disposes over a supply of copies of a physical system M that can be transferred to Bob.

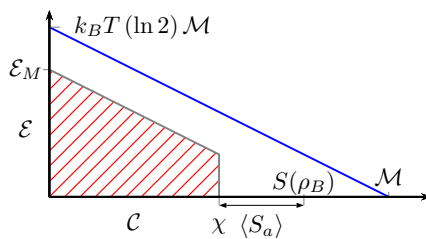

Figure 8. Graphical representation of the mutual limitation between \mathcal{E} (extractable work per letter) and \mathcal{C} (communication bits per letter) in the asymptotic limit. The hatched area contains the achievable values for \mathcal{E}, \mathcal{C} . The maximum value of \mathcal{C} is Holevo’s bound $\chi := S(\rho_B) - \langle S_a \rangle$. If Alice and Bob agree on reducing \mathcal{C} below this value, a higher value for \mathcal{E} can be achieved, with a maximum of $\mathcal{E}_M := k_B T (\ln 2) (M - \langle S_a \rangle)$. The blue line represents the case when the letters are orthogonal pure states with equal probabilities. This is the situation which offers maximum possibilities to the users.

6. Results and Conclusions

New domains for the application of quantum information theory, especially cryptography and entanglement have been presented. It is assumed that users have access to suitable QIHEs. In particular, this paper describes protocols for work extraction from a single thermal bath through the distribution of messenger qubits, with increasingly complex features. Procedures for requiring collaboration from other users to unlock work extraction are also presented using both strongly entangled and classically correlated multipartite quantum ancillas. Specifically, the following possibilities have been presented:

1. Simple transmission of messenger systems whose state is not completely depolarized for the receiver. He can extract a work equal to $k_B T (\ln 2) (S_{max} - S(\rho))$.
2. Encrypted transmission of messenger systems through the use of previously entangled bipartite systems. This technique makes the transmitted system useless for illegitimate users that might intercept them. Quantum systems prove to be able to supply twice as much work as classical ones because of the same physics that is behind the feature of superdense coding in quantum communication protocols.
3. In a multi-user scenario, where users initially share generalized GHZ states, any users can enable all the other ones to extract work.

- Also in a multi-user environment, if some correlated classical states are shared among all users, all but one can enable the other to extract work.

In order to find a relation between the two possible uses of messenger systems, a mutual limitation between communication and energy has been derived in Section 4 leading to Equation (20). This result seems quite natural, from the complementary perspectives of gaining certainty (communication) and increasing uncertainty (traded for work). In Section 5, the validity of Equation (20) is generalized to the case of simultaneously using the messenger system for communication and work extraction. The results are represented in Figure 8. It shows that the communication capacity \mathcal{C} cannot be increased over the Holevo's bound, although it can be arbitrarily reduced, upon agreement of both users, to improve the work extraction capacity up to $k_B T (\ln 2) (\mathcal{M} - \langle S_a \rangle)$.

Acknowledgments: We thank the Spanish MINECO (Ministerio de Economía y Competitividad) grant FIS2012-33152, FIS2015-67411, the CAM (Comunidad Autónoma de Madrid) research consortium QUITEMAD+S2013/ICE-2801, and the U.S. Army Research Office through grant W911NF-14-1-0103 for partial financial support.

Author Contributions: Jose M. Diaz de la Cruz and Miguel Angel Martin-Delgado conceived and discussed the contents of the article; Jose M. Diaz de la Cruz wrote the paper; Miguel Angel Martin-Delgado supervised the work. Both authors have read and approved the final manuscript.

Conflicts of Interest: The authors declare no conflict of interest.

References

- Landauer, R. Irreversibility and heat generation in the computing process. *IBM J. Res. Dev.* **1961**, *5*, 183–191.
- Bérut, A.; Arakelyan, A.; Petrosyan, A.; Ciliberto, S.; Dillenschneider, R.; Lutz, E. Experimental verification of Landauer's principle linking information and thermodynamics. *Nature* **2012**, *483*, 187–189.
- Bennett, C.H. Logical reversibility of computation. *IBM J. Res. Dev.* **1973**, *17*, 525–532.
- Feynman, R.; Shor, P.W. Simulating Physics with Computers. *SIAM J. Comput.* **1982**, *26*, 1484–1509.
- Benioff, P. Quantum mechanical Hamiltonian models of Turing machines. *J. Stat. Phys.* **1982**, *29*, 515–546.
- Deutsch, D. Quantum theory, the Church-Turing principle and the universal quantum computer. *Proc. R. Soc. Lond. Ser. A Math. Phys. Sci.* **1985**, *400*, 97–117.
- Galindo, A.; Martin-Delgado, M.A. Information and computation: Classical and quantum aspects. *Rev. Mod. Phys.* **2002**, *74*, 347–423.
- Nielsen, M.; Chuang, I. *Quantum Computation and Quantum Information*; Cambridge University Press: Cambridge, UK, 2000.
- Maxwell, J.C. *Theory of Heat*; Longmans: London, UK, 1871.
- Szilard, L. On the decrease of entropy in a thermodynamic system by the intervention of intelligent beings. *Behav. Sci.* **1964**, *9*, 301–310.
- Bennett, C.H. Demons, engines and the second law. *Sci. Am.* **1987**, *257*, 108–116.
- Zurek, W.H. Maxwell's Demon, Szilard's Engine and Quantum Measurements. In *Frontiers of Nonequilibrium Statistical Physics*; Springer: Berlin/Heidelberg, Germany, 2003.
- Kim, S.; Sagawa, T.; Liberato, S.D.; Ueda, M. Quantum Szilard engine. *Phys. Rev. Lett.* **2011**, *106*, 070401.
- Kish, L.B.; Granqvist, C.G. Energy requirement of control: Comments on Szilard's engine and Maxwell's demon. *Europhys. Lett.* **2012**, *98*, doi:10.1209/0295-5075/98/68001.
- Horowitz, J.M.; Parrondo, J.M.R. Designing optimal discrete-feedback thermodynamic engines. *New J. Phys.* **2011**, *13*, 123019.
- Diaz de la Cruz, J.M.D.; Martin-Delgado, M.A. Quantum-information engines with many-body states attaining optimal extractable work with quantum control. *Phys. Rev. A* **2014**, *89*, 032327.
- Uzdin, R.; Kosloff, R. The multilevel four-stroke swap engine and its environment. *New J. Phys.* **2014**, *16*, 095003.
- Toyabe, S.; Sagawa, T.; Ueda, M.; Muneyuki, E.; Sano, M. Information heat engine: Converting information to energy by feedback control. *Nat. Phys.* **2010**, *6*, 988–992.
- Scully, M.O. Extracting work from a single thermal bath via quantum negentropy. *Phys. Rev. Lett.* **2001**, *87*, 220601.

20. Scully, M.O.; Rostovtsev, Y.; Saryianni, Z.E.; Zubairy, M.S. Using quantum erasure to exorcize Maxwell's demon: I. Concepts and context. *Phys. E Low-Dimens. Syst. Nanostruct.* **2005**, *29*, 29–39.
21. Rostovtsev, Y.; Saryianni, Z.E.; Zubairy, M.S.; Scully, M.O. Using quantum erasure to exorcise Maxwell's demon: II. Analysis. *Phys. E Low-Dimens. Syst. Nanostruct.* **2005**, *29*, 40–46.
22. Saryianni, Z.E.; Rostovtsev, Y.; Zubairy, M.S.; Scully, M.O. Using quantum erasure to exorcize Maxwell's demon: III. Implementation. *Phys. E Low-Dimens. Syst. Nanostruct.* **2005**, *29*, 47–52.
23. Quan, H.T.; Wang, Y.D.; Liu, Y.X.; Sun, C.P.; Nori, F. Maxwell's demon assisted thermodynamic cycle in superconducting quantum circuits. *Phys. Rev. Lett.* **2006**, *97*, 180402.
24. Del Rio, L.; Aberg, J.; Renner, R.; Dahlsten, O.; Vedral, V. The Thermodynamic Meaning of Negative Entropy. *Nature* **2011**, *474*, 61–63.
25. Plesch, M.; Dahlsten, O.; Goold, J.; Vedral, V. Comment on "Quantum Szilard Engine". *Phys. Rev. Lett.* **2013**, *111*, 188901.
26. Funo, K.; Watanabe, Y.; Ueda, M. Thermodynamic work gain from entanglement. *Phys. Rev. A* **2013**, *88*, 052319.
27. Piechocinska, B. Information erasure. *Phys. Rev. A* **2000**, *61*, 062314.
28. Zhou, Y.; Segal, D. Minimal model of a heat engine: Information theory approach. *Phys. Rev. E* **2010**, *82*, 011120.
29. Lloyd, S. Quantum-mechanical Maxwell's demon. *Phys. Rev. A* **1997**, *56*, 3374–3382.
30. Vidrighin, M.D.; Dahlsten, O.; Barbieri, M.; Kim, M.S.; Vedral, V.; Walmsley, I.A. Photonic Maxwell's Demon. *Phys. Rev. Lett.* **2016**, *116*, 050401.
31. Oppenheim, J.; Horodecki, M.; Horodecki, P.; Horodecki, R. Thermodynamical approach to quantifying quantum correlations. *Phys. Rev. Lett.* **2002**, *89*, 180402.
32. Park, J.; Kim, K.; Sagawa, T.; Kim, S. Heat Engine Driven by Purely Quantum Information. *Phys. Rev. Lett.* **2013**, doi:10.1103/PhysRevLett.111.230402.
33. Ollivier, H.; Zurek, W. Quantum discord: A measure of the quantumness of correlations. *Phys. Rev. Lett.* **2002**, *88*, 017901.
34. Zurek, W.H. Quantum discord and Maxwell's demons. *Phys. Rev. A* **2003**, *67*, 012320.
35. Hasegawa, H.; Ishikawa, J.; Takara, K.; Driebe, D. Generalization of the second law for a nonequilibrium initial state. *Phys. Lett. A* **2010**, *374*, doi:10.1016/j.physleta.2009.12.042.
36. Vedral, V. The role of relative entropy in quantum information theory. *Rev. Mod. Phys.* **2002**, *74*, 197–234.
37. Sagawa, T. Second Law-Like Inequalities with Quantum Relative Entropy: An Introduction. *Stat. Mech.* **2012**, arXiv:1202.0983.
38. Brandao, F.; Horodecki, M.; Ng, N.; Oppenheim, J.; Wehner, S. The second laws of quantum thermodynamics. *Proc. Natl. Acad. Sci. USA* **2015**, *112*, 3275–3279.
39. Zheng, Y.; Poletti, D. Quantum statistics and the performance of engine cycles. *Phys. Rev. E* **2015**, *92*, 012110.
40. Jaramillo, J.; Beau, M.; del Campo, A. Quantum supremacy of many-particle thermal machines. *New J. Phys.* **2016**, *18*, 075019.
41. Beau, M.; Jaramillo, J.; del Campo, A. Scaling-up quantum heat engines efficiently via shortcuts to adiabaticity. *Entropy* **2016**, *18*, 168.
42. Jeon, H.J.; Kim, S.W. Optimal work of the quantum Szilard engine under isothermal processes with inevitable irreversibility. *New J. Phys.* **2016**, *18*, 043002.
43. Kosloff, R.; Feldmann, T. Optimal performance of reciprocating demagnetization quantum refrigerators. *Phys. Rev. E* **2010**, *82*, 011134.
44. Beretta, G.P. Quantum thermodynamic Carnot and Otto-like cycles for a two-level system. *Europhys. Lett.* **2012**, *99*, doi:10.1209/0295-5075/99/20005.
45. Gordon, G.; Bensk, G.; Gelbwaser-Klimovsky, D.; Rao, D.D.B.; Erez, N.; Kurizki, G. Cooling down quantum bits on ultrashort time scales. *New J. Phys.* **2009**, *11*, 123025.
46. Dahlsten, O.C.O.; Renner, R.; Rieper, E.; Vedral, V. Inadequacy of von Neumann entropy for characterizing extractable work. *New J. Phys.* **2011**, *13*, 053015.
47. Horodecki, M.; Oppenheim, J. Fundamental Limitations for Quantum and Nano Thermodynamics. *Nat. Commun.* **2011**, arXiv:1111.3834.
48. Egloff, D.; Dahlsten, O.C.; Renner, R.; Vedral, V. Laws of Thermodynamics beyond the von Neumann Regime. **2013**, arXiv:1207.0434.

49. Hotta, M. A protocol for quantum energy distribution. *Phys. Lett. A* **2008**, *372*, 5671–5676.
50. Hotta, M. Quantum energy teleportation with trapped ions. *Phys. Rev. A* **2009**, *80*, 042323.
51. Trevison, J.; Hotta, M. Quantum energy teleportation across a three-spin Ising chain in a Gibbs state. *J. Phys. A Math. Theor.* **2015**, *48*, 175302.
52. Ma, X.; Herbst, T.; Scheidl, T.; Wang, D.; Kropatschek, S.; Naylor, W.; Wittmann, B.; Mech, A.; Kofler, J.; Anisimova, E.; et al. Quantum teleportation over 143 kilometres using active feed-forward. *Nature* **2012**, *489*, 269–273.
53. Herbst, T.; Scheidl, T.; Fink, M.; Handsteiner, J.; Wittmann, B.; Ursin, R.; Zeilinger, A. Teleportation of entanglement over 143 km. *Proc. Natl. Acad. Sci. USA* **2015**, *112*, 14202–14205.
54. Brandão, F.G.S.L.; Horodecki, M.; Oppenheim, J.; Renes, J.M.; Spekkens, R.W. Resource theory of quantum states out of thermal equilibrium. *Phys. Rev. Lett.* **2013**, *111*, 250404.
55. Horodecki, M.; Oppenheim, J. Fundamental limitations for quantum and nanoscale thermodynamics. *Nat. Commun.* **2013**, *4*, doi:10.1038/ncomms3059.
56. Sagawa, T.; Ueda, M. Minimal energy cost for thermodynamic information processing: Measurement and information erasure. *Phys. Rev. Lett.* **2009**, *102*, 250602.
57. De Liberato, S.; Ueda, M. Carnot's theorem for nonthermal stationary reservoirs. *Phys. Rev. E* **2011**, *84*, 051122.
58. Holevo, A.S. The capacity of quantum channel with general signal states. *IEEE Trans. Inf. Theory* **1998**, *44*, 269–273.
59. Schumacher, B.; Westmoreland, M.D. Sending classical information via noisy quantum channels. *Phys. Rev. A* **1997**, *56*, 131–138.
60. Wilde, M.M. *Quantum Information Theory*; Cambridge University Press: Cambridge, UK, 2013.



© 2016 by the authors; licensee MDPI, Basel, Switzerland. This article is an open access article distributed under the terms and conditions of the Creative Commons Attribution (CC-BY) license (<http://creativecommons.org/licenses/by/4.0/>).