

Review

Biological Demalication and Deacetification of Musts and Wines: Can Wine Yeasts Make the Wine Taste Better?

Alice Vilela 

Department of Biology and Environment, Enology Building, School of Life Sciences and Environment, Chemistry Research Centre of Vila Real (CQ-VR), University of Trás-os-Montes and Alto Douro (UTAD), 5000-801 Vila Real, Portugal; avimoura@utad.pt

Received: 11 September 2017; Accepted: 27 September 2017; Published: 2 October 2017

Abstract: Grape musts sometimes reveal excess acidity. An excessive amount of organic acids negatively affect wine yeasts and yeast fermentation, and the obtained wines are characterized by an inappropriate balance between sweetness, acidity or sourness, and flavor/aroma components. An appropriate acidity, pleasant to the palate is more difficult to achieve in wines that have high acidity due to an excess of malic acid, because the *Saccharomyces* species in general, cannot effectively degrade malic acid during alcoholic fermentation. One approach to solving this problem is biological deacidification by lactic acid bacteria or non-*Saccharomyces* yeasts, like *Schizosaccharomyces pombe* that show the ability to degrade L-malic acid. Excessive volatile acidity in wine is also a problem in the wine industry. The use of free or immobilized *Saccharomyces* cells has been studied to solve both these problems since these yeasts are wine yeasts that show a good balance between taste/flavor and aromatic compounds during alcoholic fermentation. The aim of this review is to give some insights into the use of *Saccharomyces cerevisiae* strains to perform biological demalication (malic acid degradation) and deacetification (reduction of volatile acidity) of wine in an attempt to better understand their biochemistry and enological features.

Keywords: *Saccharomyces cerevisiae*; acetic acid; malic acid; mitochondrial carriers; acetic acid metabolism; malic acid metabolism; carboxylic acids transport

1. General Introduction

A balanced wine in terms of flavor should be the goal of every winemaker. Much is known about how taste components, such as acidity, sweetness, savoriness (“umami”) and alcohol can work together in coordination or discord on the palate [1–3]. In terms of organic acid content in grapes, malic acid and tartaric acid account for up to 90% of all the acids present [4,5]. The organic acid composition of the grape can be influenced by environmental factors such as light, irrigation, humidity, and temperature. However, the cultivar and growing region are also relevant for acid concentration in grapes [6]. In some cases, grape must acidity may need to be corrected. An acidity adjustment involves either acid addition or acidity reduction. In some places, grapes are harvested with a total acidity under 10 g/L or higher.

Acetic acid is the prime component of the volatile acidity of grape musts and wines. Among other causes, acetic acid can be formed as a byproduct of alcoholic fermentation or as a byproduct of the metabolism of acetic and lactic acid bacteria, which can metabolize residual sugars to increase volatile acidity. This acid has a negative impact on yeast fermentation ability and affects the quality of wines when it is present above a given concentration [7].

There are three general methods that winemakers can use to lower high acidity in dry red or white wine production: physical methods (blending and amelioration), chemical methods (bicarbonates), and biological methods (yeast and bacteria). Biological deacidification only affects the malic acid in

the total acidity of the wine, and does not reduce tartaric acid. Malolactic fermentation (MLF) is the most common method of biological deacidification or demalication. Lactic acid bacteria (LAB) have the ability to consume the malic acid and convert it to lactic acid [8]. Yeast also has the capability to consume malic acid by converting it into ethanol through malo-ethanolic deacidification. This microbiological process can cause a small increase in the wine's alcohol content; but, sometimes this is preferred over the aroma and flavor of lactic acid produced by lactic acid bacteria. It has long been known that yeasts like *Schizosaccharomyces pombe* are especially efficient at converting malic acid [9,10].

Benito et al. [11], used the co-fermentation of two non-*Saccharomyces* yeast strains in the red wine making process. *S. pombe* totally consumed the malic acid that was present, while *Lachancea thermotolerans* produced lactic acid. This process avoided the use of LAB strains to perform malolactic fermentation, thus achieving microbiological stabilization of the wine. The lactic acid produced by *L. thermotolerans* allowed the wine to achieve its potential acidity and tastiness. The final wines presented more fruity notes and contained less acetic acid and biogenic amines than the controls that had endured malolactic fermentation [11]. However, these yeasts (non-*Saccharomyces*-yeasts) have poor alcohol tolerance, so, in many cases they must be used in conjunction with *Saccharomyces* yeasts in order to complete wine fermentation. Moreover, according to van Rooyena and Tracel [9], if fermentation and deacidification using *Schizosaccharomyces* yeasts is planned, it can be expected that at the high fermentation temperatures required for complete deacidification (demalication), the wine quality will be adversely affected in comparison to the use of *Saccharomyces cerevisiae* together with induced MLF by selected strains of *Oenococcus oeni* or *Lactobacillus plantarum* [12].

Regarding excessive volatile acidity in wines, the available solutions (blending the filter-sterilized acidic wine with other wines of lower volatile acidity or using reverse osmosis [13]) are unsatisfactory due to the detrimental aroma/flavor of the final wine. We have studied an empirical biological deacidification process, previously discussed by Ribéreau-Gayon et al. [14], that aims to lower the volatile acidity of wines. This process consists in refermenting the acidic wines by mixing them with marc from a finished wine fermentation, freshly crushed grapes or musts. During the refermentation process acetic acid is consumed by yeasts [15]. We found that indigenous, as well as commercial wine yeasts, were able to metabolize acetic acid during alcoholic fermentation [15] and that deacidification could also be performed directly in acidic wines, without the addition of sugar [16].

Some genomic and hybridization approaches, including global transcription machinery engineering [17], to induce genetic variation have been employed to construct genetically modified yeast able to consume/degrade malic acid and acetic acid. Aiming to select new yeast strains for the industry, several strategies have been applied (Figure 1): (A) Exploring the diversity of natural yeasts from yeast collections, and by studying genotype–phenotype interactions and selecting the most interesting variants; (B) Combining the genomes of multiple strains, thus generating diversity; the new strains obtained are considered non-genetically modified yeasts, so they can be used without restrictions in the industry; and (C) Genetically engineering a new strain by recombining a specific gene (piece of DNA) that is known to confer a specific relevant phenotype for the industry [17]. However, this technique genetically modifies yeasts. Due to the controversy regarding the use of genetically modified organisms, and because of consumer concerns, strains generated using this technique are unlikely to be commercially viable in the near future [18].

Wild yeast strains and their hybrids can be effectively used in acidic grape must fermentation. Another approach to performing demalication consists in improving L-malic acid decomposition on a molecular level. The bacterial *mleA* genes from *Oenococcus oeni* and the *mae1* genes (malate permease) from *Schizosaccharomyces pombe* yeast were cloned and co-expressed in *S. cerevisiae* [19]. The co-expression of the *Candida utilis* malic enzyme gene (*cme1*) and *S. pombe* malate transporter gene (*mae1*) in *S. cerevisiae* resulted in complete malate consumption [20]. However, only the work of Husnik et al. [19] was productive; the authors were able to construct a stable genetically engineered wine *S. cerevisiae* yeast, carrying the *mae1* and *mleA* genes. The recombinant yeast received GRAS status (Generally Recognized as Safe) and is currently commercialized in Moldova and the USA [21].

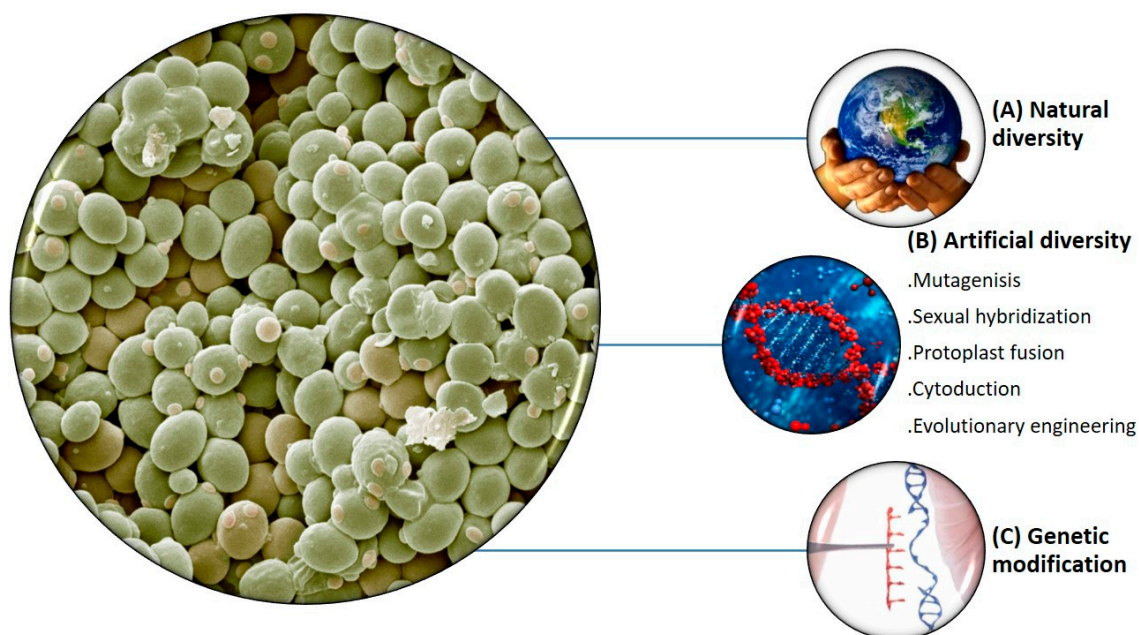

Figure 1. Overview of strategies to obtain superior industrial yeast strains: (A) Natural diversity; (B) Artificial diversity and (C) Genetic modification. Adapted from Steensels et al. [17].

In 2012, Kunicka-Styczynska and Rajkowska [22] examined the characterization of six commercial wine yeasts expressing high demalication activity. To promote L-malic acid fermentation and alcoholic fermentation, simultaneously, the wine yeasts *S. cerevisiae* and *S. bayanus* var. *uvarum* were crossed, and the natural hybrids were obtained. The hybrids were able to decompose up to 77% of malic acid present in musts [23]. In another study, Redzepovic et al. [24] worked with *Saccharomyces paradoxus* yeast strain isolated from Croatian grapes, as with *S. bayanus* and *S. cerevisiae* (Lalvin and Lallemand-France).

As mentioned, several molecular methods have been developed for bio-deacidification in order to achieve wines with a fine equilibrium between sugar and acid, however, they are limited to the metabolism of malic acid [19,25–29]. Nonetheless, genetically modified strains that substantially decrease acetate yields have been obtained [30–33].

2. Uptake of Malic Acid into the Yeast Cell

Carboxylic acids are organic compounds that participate in many cellular processes. Previous research has been carried out on yeasts in an effort to characterize the mechanisms of transport of these acids across the yeast cell membrane. Carboxylic acids are weak acids, they partially dissociate in aqueous systems. There is an equilibrium between undissociated, uncharged molecules and their anionic form(s), according to their pKa and to the pH of the medium. This property is important as it influences cell behavior and the mechanisms by which the acids can cross the yeast membrane [34].

The transport mechanisms of carboxylic acids can be mediated or non-mediated; passive (Figure 2A) or active (Figure 2B), energy-independent or dependent (Figure 2). In (Figure 2A), simple diffusion (Figure 2A₁) occurs, and/or facilitated diffusion mediated by a channel or permease protein transport (Figure 2A₂), and this involves the transport of the uncharged/undissociated form of the acid. At low pH, the undissociated form of the acid is favored and it may cross the cell membrane by simple diffusion because it is lipid-soluble (Figure 2). Inside the cell cytoplasm, the neutral pH leads to the dissociation of the acid and the acid anion accumulates [34].

The active transport system (Figure 2B), is provided by two distinct processes: B₁-pumps associated with yeast stress responses. The extrusion of the anion form of the acid accumulated in the cytoplasm occurs; and permeases B₂-associated with metabolic routes of nonfermentable

carbon sources [34]. All these transmembrane transporters are currently classified by the Transport Classification Database (<http://www.tcdb.org>).

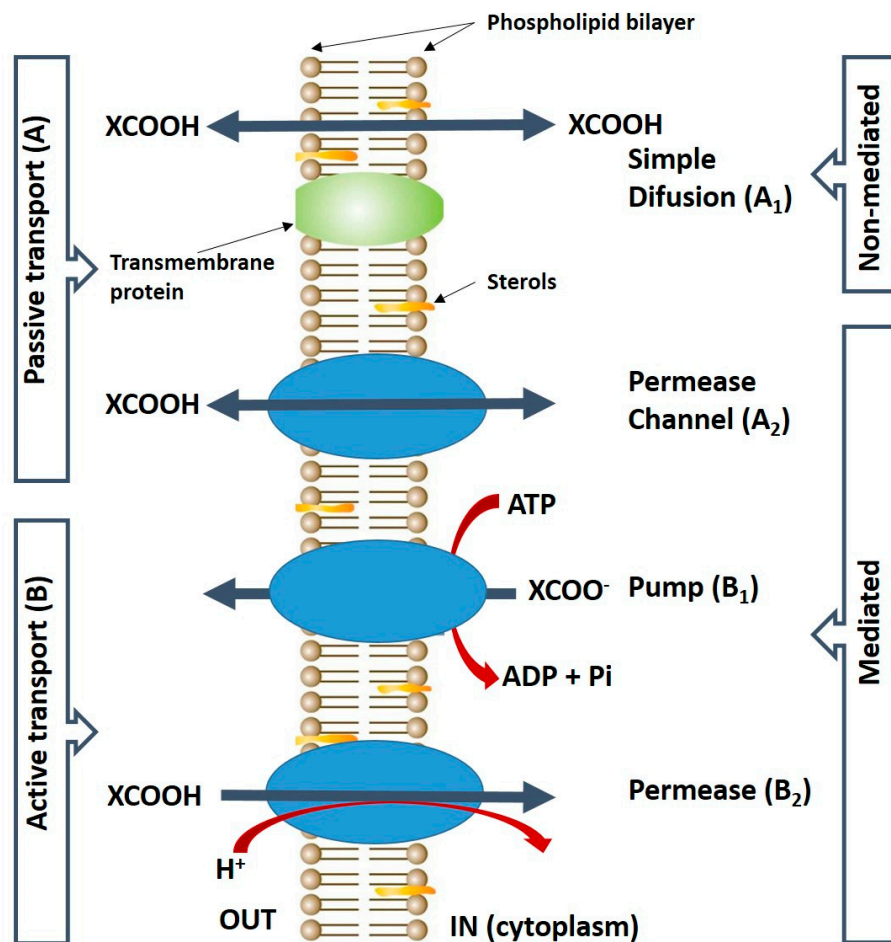

Figure 2. Schematic representation of the carboxylic acids transport systems in the yeast cell membrane: Carriers (transporters) are represented by the three blue-oval shapes; XCOOH, carboxylic acid. XCOO⁻, anion form of the acid. Adapted from Casal et al. [34].

The yeast *S. cerevisiae* has long been known as a poor metabolizer of extracellular malate, due to the lack of a mediated transport system for the acid [35]. The ability of a yeast strain to degrade extracellular L-malate is dependent, among other reasons, for the efficient transport of the dicarboxylic acid into the cell. *S. cerevisiae* lacks an active transport system for L-malate and extracellular L-malate enters the cells by means of simple diffusion (Figure 2A₁); Moreover, the malic enzyme of *S. cerevisiae* has a considerably lower substrate affinity for L-malate ($K_m = 50 \text{ mM}$) [21]; and the *S. cerevisiae* malic enzyme is mitochondrial, whereas the *S. pombe* malic enzyme is cytosolic [36].

It is also known that strains of *S. pombe* and *Zygosaccharomyces bailii* can metabolize L-malate in the presence of glucose or another assimilable carbon source [37]. In contrast, *Hansenula anomala*, *Candida sphaerica*, *Pichia stipitis* and *Pachysolen tannophilus* are yeasts species able to utilize malic acid as a sole carbon source, although this skill is repressed in the presence of glucose [38]. Low efficiencies on malic acid metabolism have been observed for *S. cerevisiae*, *Candida colliculosa*, *Candida stellata*, and *Hanseniaspora uvarum*/*Kloeckera apiculata* [21].

As mentioned above, the ability of a yeast strain to degrade extracellular L-malate is dependent on the efficient transport of the dicarboxylic acid into the cell. The yeasts *C. utilis*, *C. sphaerica*, *H. anomala* and *K. marxianus* are able to transport malate by a proton symport/induced and glucose

repressed system [21,39–41], while the transport of this acid is carrier-mediated in *Kluyveromyces lactis* (active transport/strain dependent and glucose repressed [42]). *Z. bailii* is also able to transport L-malate by facilitated diffusion for non-dissociated form and the transport is induced by glucose and repressed by fructose [43]. *Schizosaccharomyces pombe* possesses a proton symport/constitutive transport system [21].

3. The Demalication Activity of *Saccharomyces* Strains

The ability of *Saccharomyces* strains to degrade malic acid is strain dependent [24,44,45]. The rather low malate consumption can be explained by the absence of an active L-malate carrier, low substrate affinity and the mitochondrial location of the malic enzyme [46–48]. The malic enzyme, under fermentation conditions is regulated by the fermentative glucose metabolism that causes mitochondrial deterioration [20].

Redzepovic et al. [24] found that the indigenous *Saccharomyces paradoxus* strain RO88 degraded 38% of the malic acid in chardonnay must. The wine produced was of good quality; while *S. pombe* strain removed a much higher value of malic acid (90%), the wine produced was of poor quality. In the same study, the authors verified that *S. cerevisiae* Lalvin strain 71B, commercially promoted as a “malic-acid-degrading wine strain”, only degraded 18% of the malic acid. However, expression of the malic enzyme gene from *S. paradoxus* RO88 and *S. cerevisiae* 71B increased towards the end of fermentation, after glucose depletion.

3.1. Dicarboxylate Carrier *Dic1p* (YLR348c) in Yeasts

Lancar-Benba et al. [49] in 1996 isolated the dicarboxylates carrier protein *Dic1p*, from the mitochondria of yeast. The *Dic1p* carrier protein transports malate, succinate or malonate. Other molecules such as sulphate and thiosulphate are also exchanged by *Dic1p* for malate or phosphate. Additionally, this carrier protein is inhibited by the substrate equivalents butylmalonate, benzylmalonate and phenylsuccinate. The K_m (transport affinity) of *Dic1p* for phosphate is 1.65 mM and for malate it is 0.56 mM [50].

To understand the physiological role of the *Dic1p* carrier Palmieri et al. [51] constructed a yeast mutant with its depleted gene. They found that there is no other mitochondrial transport system capable of replacing the dicarboxylate carrier studied by Palmieri et al. [52]. This indicates that the main function of the *Dic1p* carrier is to transport cytoplasmic dicarboxylates into the mitochondrial matrix, working as an essential anaplerotic transporter for the Krebs cycle. The *Dic1p* carrier catalyzes the import of succinate into mitochondria in exchange for internal phosphate, in wild-type *S. cerevisiae* growing on ethanol or acetate (Figure 3).

Since phosphate is reprocessed into mitochondria by the *Mir1p* phosphate carrier, the combined activity of the *Dic1p* and *Mir1p* carriers is responsible for the uptake of succinate. Succinate is converted to fumarate, and, subsequently, to oxaloacetate. These reactions that occur within the mitochondria allow the oxidation of acetyl-CoA formally produced from acetate or ethanol (Figure 3).

3.2. The Aspartate/Glutamate Carrier *Agc1p* (YPR021c) in Yeasts

The product of the yeast gene *YPR021c* was identified by the “similarity approach” as the yeast orthologue of human AGCs (mitochondrial aspartate/glutamate carriers) and was named *Agc1p* [51]. It has no N-terminal EF-hand motifs, but the C-terminal domain of *Agc1p* is 44% identical to AGC1 and 43% identical to AGC2 corresponding domains. *Agc1p* (C-terminal part) transport properties are indicative that *Agc1p* is an aspartate/glutamate carrier [53]. AGC performs a key role in the malate/aspartate NADH shuttle in mammalian mitochondria. It promotes the transference of reducing equivalents from the cytosol to the mitochondrial matrix, for electron transport. In yeasts, the enzymes required to complete this shuttle function are also present, but there are some questions about the role of the NADH shuttle [51].

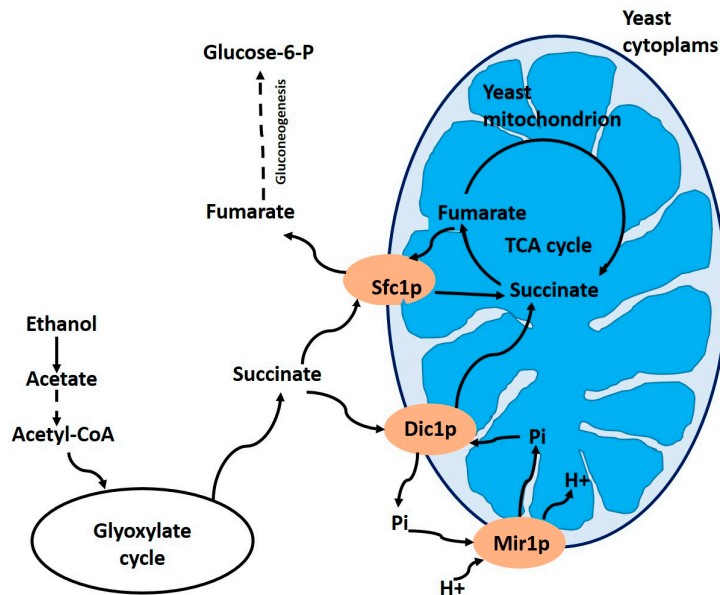

Figure 3. Schematic representation of the actions of the mitochondrial Dic1p carrier and the Sfc1p mitochondrial succinate/fumarate carrier, when yeast cells are grown on acetate or ethanol as the sole carbon source. Abbreviations: TCA cycle, tricarboxylic acid cycle; Mir1p, mitochondrial phosphate carrier; Pi, phosphate. Adapted from Palmieri et al. [51].

Cavero et al. [53] characterized the physiological role of the Agc1p carrier, and deleted the AGC1 gene from two *S. cerevisiae* strains (W303 and YPH499). The resultant mutants were not able to grow in minimal synthetic medium supplemented with acetate or oleic acid. Surprisingly they showed viability and grow in a medium supplemented with other non-fermentable carbon sources like ethanol [53]. The hypothesis formulated was that the Agc1p carrier plays a role in the malate/aspartate shuttle, and this role is critical for growth on acetate and fatty acids (Figure 4).

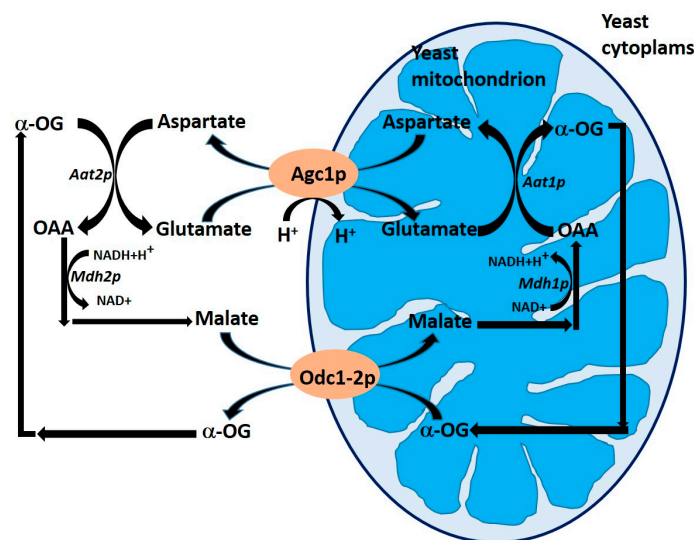

Figure 4. Schematic representation of the role of oxodicarboxylate Odc1p and Odc2p and mitochondrial aspartate/glutamate Agc1p carriers in the malate/aspartate transport system. Abbreviations: Aat1p, mitochondrial aspartate aminotransferase; Aat2p, cytosolic aspartate aminotransferase; Mdh1p, mitochondrial malate dehydrogenase; Mdh2p, cytosolic malate dehydrogenase; α-OG, 2-oxoglutarate; OAA, oxaloacetate. Adapted from Palmieri et al. [51].

4. Acetic Acid Metabolism in *S. cerevisiae*

The aroma threshold for acetic acid in wine, depends on the wine variety and style; a concentration of 0.8–0.9 g/L produces a sour aftertaste in wine [54]. According to current legislation [55], the maximum acceptable limit for volatile acidity in red and white table wines is 1.2 g/L of acetic acid [55].

S. cerevisiae is able to metabolize acetic acid during a refermentation process [14,56]. According to the authors and the work done by Vilela-Moura et al. [7,15,16,56] and Vasserot et al. [57], excessive volatile acidity can be removed by re-inoculating (performing a refermentation) with an appropriate *S. cerevisiae* wine yeast. Under aerobic conditions, acetate can be used as a carbon and energy source for the generation of energy and cellular biomass [58]. In *S. cerevisiae*, acetate transport and metabolism are subject to glucose repression. However, in chemostat cultures of *S. cerevisiae* grown in mixtures of acetic acid and glucose, if the glucose concentration is extremely low, the cells will no longer be repressed and will metabolize acetate concomitantly with glucose [59]. In a review by Vilela-Moura et al. [7] it is considered that the cellular uptake/transport of acetate into the yeast cell is an important step for its catabolism. In glucose-repressed yeast cells, at low pH, acetic acid enters mainly by simple diffusion [60]. Ethanol will enhance the passive influx of acetic acid, following the first-order kinetics with a constant rate, which increases exponentially with ethanol concentration [61], see Figure 5.

In 1999, Casal et al. [62] found that the transport carrier Jen1p is required for the uptake of lactate in *S. cerevisiae*. This transporter is also able to transport acetate. Later, it was found that the protein Ady2p was vital for acetate transport in acetic acid-grown cells [63]. Being the only available energy and carbon source, acetate is metabolized to acetyl coenzyme A (acetyl-CoA) by one of the two ACS proteins: Acs1p (peroxisomal) or Acs2p (cytosolic). Acetyl-CoA enters the mitochondria and is then oxidized in the TCA cycle. Acetyl-CoA, by entering the glyoxylate cycle, is also used to produce succinate, refilling the cell with biosynthetic precursors (Figure 5). This action involves the enzymes Icl1p (isocitrate lyase) in the cytosol, and Mls1p (malate synthase) located in the peroxisome [7]. Moreover, acetyl-CoA is used for the synthesis of macromolecules, requiring active gluconeogenesis [64].

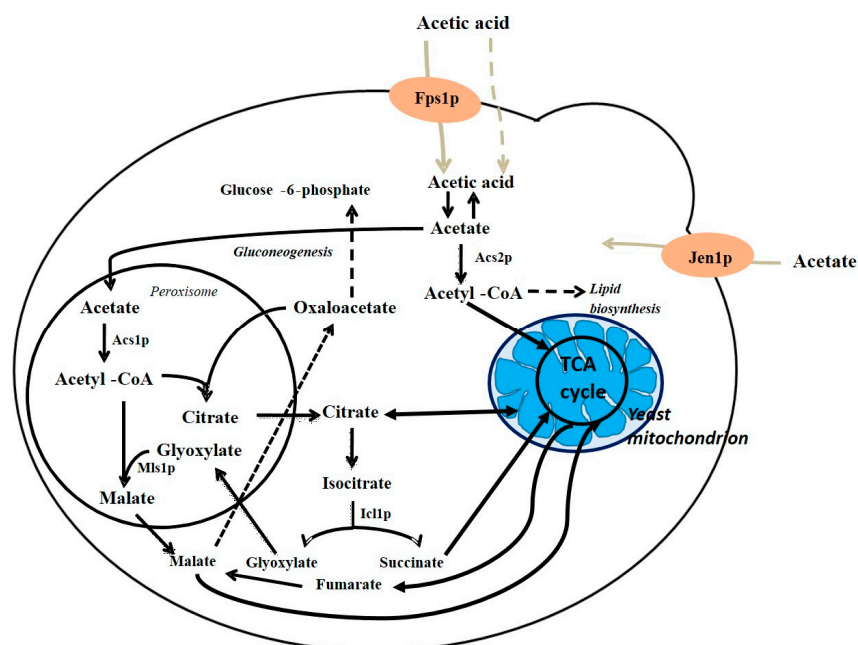

Figure 5. Cell compartmentation of acetate metabolism in yeast: Black arrows show metabolic pathways and light brown arrows represent acetic acid or acetate transport systems; Fps1p, aquaglyceroporin that mediates the transport of the undissociated form of acetic acid across yeast membranes (solid line); Acetic acid can also enter the cell by simple diffusion (dotted line); Jen1p, *S. cerevisiae* lactate transporter that is also able to transport acetate. Adapted from Vilela-Moura [64].

VA Bio-Reduction by *S. cerevisiae* Yeasts Strains and its Limitations

Consumption of glucose and acetic acid is a characteristic of indigenous and commercial wine yeasts [15,65]. In these works [15,65] the characterization of indigenous and commercial *S. cerevisiae* strains regarding volatile acidity bio-reduction was performed. Among the strains studied, some exhibited a simultaneous consumption pattern of glucose and acetic acid in refermentation assays of acidic white wines with a synthetic culture medium simulating refermentation with a must (conditions of high glucose/low ethanol concentrations) and refermentation with a marc (conditions of low glucose/high ethanol concentrations). Under conditions where oxygen is limited, all the *S. cerevisiae* strains studied showed acetic acid degradation efficiencies like those of *Z. bailii* ISA 1307. Curiously, the commercial strain S26 also revealed the capacity to decrease the volatile acidity of wines in aerobic and limited aerobic conditions by 92% and 61%, respectively [15].

Upon inoculation of grape must or wine, a controlled oxygen environment is important for yeast acetic acid consumption [15]. Moreover, yeast cells need to adapt to the hostile fermentation environment, which gradually changes over time. In fermentation or refermentation, multiple stress conditions are imposed on the yeast cell such as high osmolarity; low pH; sulfur dioxide (SO₂); ethanol toxicity; temperature variations; increasing nitrogen limitation; and elevated acetic acid concentrations. All of these stress conditions may lead to reduced cellular growth, cellular death and, consequently, stuck fermentations [14,66–68].

A controlled wine oxygenation can be accomplished through micro-oxygenation (MO) where oxygen is added by a stainless steel sparger that produces small bubbles, promoting oxygen dissolution in the must/wine. The influence of different combinations of the initial concentration of acetic acid, ethanol, SO₂ and MO on acetic acid removal from wines with an excessive volatile acidity, by two commercial yeasts strains (S26 and S29) was evaluated [16,56]. Both strains (*S. cerevisiae* S26 and S29) reduced by 78% and 48%, respectively, the volatile acidity of an acidic wine with an initial concentration of 1.0 g/L in acetic acid. Sulfur dioxide in the concentration range of 95–170 mg/L inhibited the capacity of both strains to reduce the volatile acidity under the experimental conditions used. Deacetication of wines with the better performing strain, S26, was related to changes in the concentration of wine volatile compounds. The most pronounced increase was observed for compounds with a fruity flavor: isoamyl acetate and ethyl hexanoate with banana-like flavor and apple-pineapple-like flavor, with an 18- and 25-fold increment, respectively; both values above the detection threshold. Furthermore, deacetication led to increased fatty acids concentration, but with apparently no negative impact on the wine's sensorial properties [16]. However, in the work of Vasserot et al. [57], the results were not as promising. In their work, a commercial *S. cerevisiae* strain, used in champagne winemaking, was tested for its ability to metabolize acetic acid during fermentation. The amount of acetic acid metabolized by the yeast strain increased with increasing initial acetic acid concentration. The consumption of acetic acid occurred during the second part of the exponential growth phase. However, when the initial acetic acid concentration was higher than 1.0 g/L, independently of the yeast strain used, the final acetic acid concentration could not be reduced to a legally acceptable level [55]. Acetic acid consumption modified yeast metabolism once more acetaldehyde (with a tart flavor reminiscent of green apples) and less glycerol (reduced wine softness) were produced. Considering the reduction of the NADPH/NADP⁺ (Nicotinamide Adenine Dinucleotide Phosphate reduced/Nicotinamide Adenine Dinucleotide Phosphate oxidized) ratio, resulting in acetic acid consumption, Vasserot et al. [57] proposed that acetic acid modifies yeast metabolism by reducing the Ald6p activity (NADP⁺ dependent aldehyde dehydrogenase).

In 2010, Vilela-Moura et al. [56], based on other previous studies of indigenous *S. cerevisiae* strains [15], tested the applicability of the *S. cerevisiae* strains (S26 and S29) for the deacidification of a white wine (from *V. vinifera* cv. Viosinho) and a red wine (from *V. vinifera* cv. Touriga Nacional), in a pilot study. The initial volatile acidity of the musts-wines was between 1.12–1.15 g/L acetic acid [56]. Moreover, the effect of the refermentation process on the red wine, and of MO on acetic acid removal efficiency and aromatic composition of the wine was also studied.

The results showed that the commercial strains S26 and S29 efficiently reduced acetic acid (43 and 47%, respectively) and sugar (100%) after 264 h of refermentation of the acidic white wine that had grape must added. For red wine deacidification, by using grape must independently of MO, it was observed that 60%–66% of the acetic acid was removed. Wines refermented with the must had significantly lower acetic acid concentration and a higher total SO₂ in comparison to the wines deacidified with the addition of grape marcs. The composition of the volatile aroma compounds of the resulting red wines was dependent on the deacidification process used, rather than on MO. Conversely, when residual marc from fermentation and strain S26 was used, the aromatic profile of wine changed and the concentration of aromatic esters increased. Esters are well known for their positive contribution to the wine bouquet with strong fruity aromatic notes. Independently of MO, esters such as ethyl isovalerate (fruity-flavor [69]), ethyl isobutyrate (strawberry, ethereal, buttery, ripe-flavor [69]), ethyl 2-methylbutyrate (sweet, floral, fruity, apple flavor [69]) and ethyl propionate (rum-like flavor [69]), were found in higher concentrations [56]. Contrary to what was found by Vasserot et al. [57], the final concentration of acetaldehyde was rather low. The initial concentration in acidic red wine/must and red wine/marc mixtures was 14.3 and 20.0 mg/L, respectively, and increased during deacidification to values between 21–86 mg/L, below the detection limit, that is 100 mg/L [70].

The best sensory classification was gained by the marc-deacidified wine obtained by the use of strain S26 and without MO. Oral perception and aroma (orthonasal sensations) were the sensorial qualities that best distinguished the wines. When data from all analytical and sensorial evaluations were combined, a correlation made by PCA (Principal Component analysis based on correlation matrix) separated the wines into three groups. The separation was according to the strain (S26 or S29) and the refermentation process (must or marc) independent of the oxygen addition (MO), Figure 6 [56].

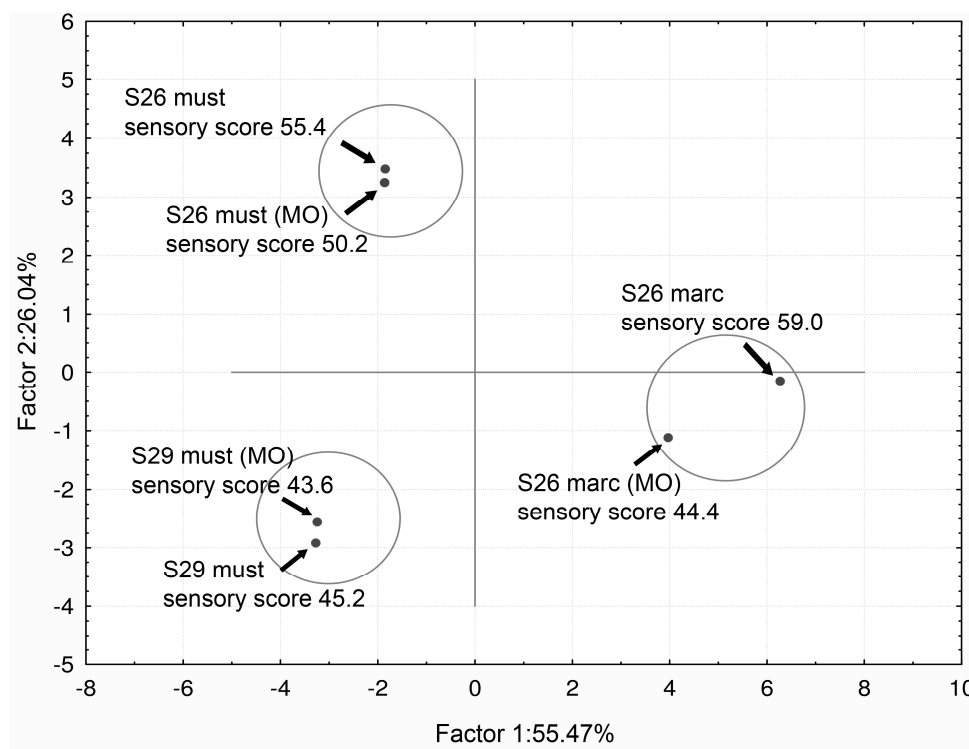

Figure 6. Bi-dimensional plot of principal component analysis (PCA) values after combining data from chemical and sensorial analysis. Projection of the data according to the strains and the deacidification process. Adapted from Vilela-Moura et al. [56].

As mentioned before, yeast cells need to adapt to a hostile environment during fermentation or refermentation, so, cell immobilization by entrapment in beads is a technique that offers some

advantages like continuous cell utilization; protection of immobilized cells against inhibitory substances in the fermentation medium; increased fermentation rates; stimulation of production, and protection from shear forces [71]. In 2013 Vilela et al. [72]. studied the efficiency of acetic acid consumption by the previously characterized commercial S26 strain, but the cells were immobilized in a matrix of alginate-chitosan. Several important parameters were analyzed such as initial pH; number/composition of the immobilization matrix; cell concentration and deacetication process efficiency. Immobilized cells were able to reduce 21.6% of the initial volatile acidity 72 h after inoculation. The initial acidic wine had a concentration of 1.1 g/L of acetic acid; ethanol 12.5% (*v/v*) and a pH of 3.5 h. However, deacetication did not change after 168 h and was accompanied by a slight decrease in ethanol concentration and cell leakage. Initial wine pH adjustment to 3.12 and duplication of initial cell concentration led to an increase in volatile acidity removal up to 61.8%, and no cell leakage from the beads was observed [72].

5. Final Remarks

Production of premium wines is dependent on the optimal adjustment of wine acidity in relation to the other wine components, thus obtaining a balanced wine with an optimum flavor, color and texture profile. The conversion of L-malic acid to L-lactic acid during malolactic fermentation by strains of Lactic Acid Bacteria (LAB) is the traditional method used by winemakers to deacidify wines. Nonetheless, due to intrinsic problems associated with malolactic fermentation (production of acetic acid, for instance) and its unsuitability in some fruity floral wines, other biological methods for the deacidification of wines will be of great benefit to the wine industry.

The use of wine yeast strains with the ability to consume malic acid will reduce the use of LAB and other cellar operations conducted to reduce acidity. Genetically engineered yeasts are considered efficient in malate metabolism but, they cannot always be used because they lack GRAS status. However, the hybrids produced by the natural hybridization of wine yeast are safe but sometimes, and this is a major concern, it is impossible to maintain their genetic stability which can mainly be improved in the process of adaptive evolution. Additionally, many wine yeasts already considered commercial strains, are interspecific hybrids between yeasts of the *Saccharomyces sensu stricto* complex.

The metabolic influence of yeast on the volatile acidity of wine is undisputable and the right selection of yeast strains determines the performance of the fermentation or refermentation process, leading to higher quality wine. To meet winemakers' demands, there is an endless search for new wine yeast strains to be used in highly acidic musts and wines. Deacetication of wine with a *S. cerevisiae* yeast strain may eliminate the use of physical methods like reverse-osmosis or blending wines to decrease volatile acidity, which in turn will reduce the economic losses endured by winemakers.

Acknowledgments: This work is supported by the Chemistry Research Centre of Vila Real (CQ-VR). Additional thanks to the Project NORTE-01-0145-FEDER-000038 (I&D INNOVINE&WINE–Innovation Platform of Vine & Wine).

Conflicts of Interest: The author declare no conflict of interest.

References

1. Vilela, A.; Inês, A.; Cosme, F. Is wine savory? Umami taste in wine. *SDRP J. Food Sci. Technol.* **2016**, *1*, 1–6.
2. Vilela, A.; Jordão, A.M.; Cosme, F. Wine phenolics: Looking for a smooth mouthfeel. *SDRP J. Food Sci. Technol.* **2016**, *1*, 1–8. [[CrossRef](#)]
3. Jordão, A.M.; Vilela, A.; Cosme, F. From Sugar of Grape to Alcohol of Wine: Sensorial Impact of Alcohol in Wine. *Beverages* **2015**, *1*, 292–310. [[CrossRef](#)]
4. Torija, M.J.; Beltran, G.; Novo, M.; Poblet, M.; Rozès, N.; Mas, A.; Guillamón, J.M. Effect of organic acids and nitrogen source on alcoholic fermentation: Study of their buffering capacity. *J. Agric. Food Chem.* **2003**, *51*, 916–922. [[CrossRef](#)] [[PubMed](#)]
5. Liu, H.F.; Wu, B.H.; Fan, P.G.; Li, S.H.; Li, L.S. Sugar and acid concentrations in 98 grape cultivars analyzed by principal component analysis. *J. Sci. Food Agric.* **2006**, *86*, 1526–1536. [[CrossRef](#)]

6. Lamikanra, O.; Inyang, I.; Leong, S. Distribution and effect of grape maturity on organic acid content of red Muscadine grapes. *J. Agric. Food Chem.* **1995**, *43*, 3026–3028. [[CrossRef](#)]
7. Vilela-Moura, A.; Schuller, D.; Mendes-Faia, A.; Silva, R.F.; Chaves, S.R.; Sousa, M.J.; Côte-Real, M. The impact of acetate metabolism on yeast fermentative performance and wine quality: Reduction of volatile acidity of grape-musts and wines—Minireview. *Appl. Microbiol. Biotechnol.* **2011**, *89*, 271–280. [[CrossRef](#)]
8. Inês, A.; Tenreiro, T.; Tenreiro, R.; Mendes-Faia, A. Revisão: As bactérias do ácido láctico do vinho-Parte I. *Ciênc. Téc. Vitiviníc.* **2008**, *23*, 81–96.
9. Van Rooyen, T.J.; Tracel, R.P. Biological Deacidification of Musts Induced by Yeasts or Malolactic Bacteria and the Effect on Wine Quality. *S. Afr. J. Enol. Vitic.* **1987**, *8*, 60–69. [[CrossRef](#)]
10. Camarasa, C.; Bidard, F.; Bony, M.; Barre, P.; Dequin, S. Characterization of *Schizosaccharomyces pombe* Malate Permease by Expression in *Saccharomyces cerevisiae*. *Appl. Environ. Microbiol.* **2001**, *67*, 4144–4151. [[CrossRef](#)] [[PubMed](#)]
11. Benito, A.; Calderón, F.; Palomero, F.; Benito, S. Combined use of selected *Schizosaccharomyces pombe* and *Lachancea thermotolerans* yeast strains as an alternative to the traditional malolactic fermentation in red wine production. *Molecules* **2015**, *20*, 9510–9523. [[CrossRef](#)] [[PubMed](#)]
12. Petruzzi, L.; Capozzi, V.; Berbegal, C.; Corbo, M.R.; Bevilacqua, A.; Spano, G.; Sinigaglia, M. Microbial resources and enological significance: Opportunities and benefits. *Front. Microbiol.* **2017**, *8*, 1–13. [[CrossRef](#)] [[PubMed](#)]
13. Zoecklein, B.W.; Fugelsang, K.C.; Gump, B.H.; Nury, F.S. Volatile acidity. In *Wine Analysis and Production*, 1st ed.; Chapman & Hall: New York, NY, USA, 1995; pp. 192–198. ISBN 978-1-4757-6967-8.
14. Ribéreau-Gayon, P.; Dubourdieu, D.; Donèche, B.; Lonvaud, A. The microbiology of wine and vinifications. In *Handbook of Enology*, 1st ed.; John Wiley & Sons Ltd.: Chichester, UK, 2000; Volume 1, p. 454. ISBN 13:978-0-470-01034-1 (HB).
15. Vilela-Moura, A.; Schuller, D.; Mendes-Faia, A.; Côte-Real, M. Reduction of volatile acidity of wines by selected yeast strains. *Appl. Microbiol. Biotechnol.* **2008**, *80*, 881–890. [[CrossRef](#)] [[PubMed](#)]
16. Vilela-Moura, A.; Schuller, D.; Mendes-Faia, A.; Côte-Real, M. Effects of acetic acid, ethanol and SO₂ on the removal of volatile acidity from acidic wines by two *Saccharomyces cerevisiae* commercial strains. *Appl. Microbiol. Biotechnol.* **2010**, *87*, 1317–1326. [[CrossRef](#)] [[PubMed](#)]
17. Steensels, J.; Snoek, T.; Meersman, E.; Nicolino, M.P.; Voordeckers, K.; Verstrepen, K.J. Improving industrial yeast strains: Exploiting natural and artificial diversity. *Fems Microbiol. Rev.* **2014**, *38*, 947–995. [[CrossRef](#)] [[PubMed](#)]
18. Schuller, D. Better yeast for better wine—Genetic improvement of *Saccharomyces cerevisiae* winemaking strains. In *Progress in Mycology*; Rai, M., Kövics, G., Eds.; Scientific Publishers: Jodhpur, India, 2010; pp. 1–51. ISBN 978-90-481-3713-8.
19. Husnik, J.I.; Volschenk, H.; Bauer, J.; Colavizza, D.; Luo, Z.; van Vuuren, H.J. Metabolic engineering of malolactic wine yeast. *Metab. Eng.* **2006**, *8*, 315–323. [[CrossRef](#)] [[PubMed](#)]
20. Saayman, M.; van Zyl, W.H.; Viljoen-Bloom, M. Cloning, characterization, and heterologous expression of the *Candida utilis* malic enzyme gene. *Curr. Genet.* **2006**, *49*, 248–258. [[CrossRef](#)] [[PubMed](#)]
21. Saayman, M.; Viljoen-Bloom, M. The biochemistry of malic acid metabolism by wine yeasts—A review. *S. Afr. J. Enol. Vitic.* **2006**, *27*, 113–122. [[CrossRef](#)]
22. Kunicka-Styczynska, A.; Rajkowska, K. Phenotypic and genotypic diversity of wine yeasts used for acidic musts. *World J. Microbiol. Biotechnol.* **2012**, *28*, 1929–1940. [[CrossRef](#)] [[PubMed](#)]
23. Kunicka-Styczynska, A.; Rajkowska, K. Physiological and genetic stability of hybrids of industrial wine yeasts *Saccharomyces sensu stricto* complex. *J. Appl. Microbiol.* **2011**, *110*, 1538–1549. [[CrossRef](#)] [[PubMed](#)]
24. Redzepovic, S.; Orlic, S.; Majdak, A.; Kozina, B.; Volschenk, H.; Viljoen-Bloom, M. Differential malic acid degradation by selected strains of *Saccharomyces* during alcoholic fermentation. *Int. J. Food Microbiol.* **2003**, *83*, 49–61. [[CrossRef](#)]
25. Bony, M.; Bidart, F.; Camarasa, C.; Ansanay, V.; Dulau, L.; Barre, P.; Dequin, S. Metabolic analysis of *S. cerevisiae* strains engineered for malolactic fermentation. *FEBS Lett.* **1997**, *410*, 452–456. [[CrossRef](#)]
26. Husnik, J.I.; Delaquis, P.J.; Cliff, M.A.; van Vuuren, H.J.J. Functional analyses of the malolactic wine yeast ml01. *Am. J. Enol. Vitic.* **2007**, *58*, 42–52.

27. Main, G.L.; Threlfall, R.T.; Morris, J.R. Reduction of malic acid in wine using natural and genetically enhanced microorganisms. *Am. J. Enol. Vitic.* **2007**, *58*, 341–345.
28. Silva, S.; Ramon-Portugal, F.; Andrade, P.; Abreu, S.; Teixeira, M.D.; Strehaiano, P. Malic acid consumption by dry immobilized cells of *Schizosaccharomyces pombe*. *Am. J. Enol. Vitic.* **2003**, *54*, 50–55.
29. Sousa, M.J.; Teixeira, J.A.; Mota, M. Must deacidification with an induced flocculent yeast strain of *Schizosaccharomyces pombe*. *Appl. Microbiol. Biotechnol.* **1993**, *39*, 189–193. [[CrossRef](#)]
30. Remize, F.; Andrieu, E.; Dequin, S. Engineering of the pyruvate dehydrogenase bypass in *Saccharomyces cerevisiae*: role of the cytosolic Mg²⁺ and mitochondrial K⁺ acetaldehyde dehydrogenases Ald6p and Ald4p in acetate formation during alcoholic fermentation. *Appl. Environ. Microbiol.* **2000**, *66*, 3151–3159. [[CrossRef](#)] [[PubMed](#)]
31. Walkey, C.J.; Luo, Z.; Madilao, L.L.; van Vuuren, H.J.J. The Fermentation Stress Response Protein Aaf1p/Yml081Wp Regulates Acetate Production in *Saccharomyces cerevisiae*. *PLoS ONE* **2012**, *7*, e51551. [[CrossRef](#)] [[PubMed](#)]
32. Cordente, A.G.; Cordero-Bueso, G.; Pretorius, I.S.; Curtin, C.D. Novel wine yeast with mutations in YAP1 that produce less acetic acid during fermentation. *FEMS Yeast Res.* **2013**, *13*, 62–73. [[CrossRef](#)] [[PubMed](#)]
33. Luo, Z.; Walkey, C.J.; Madilao, L.L.; Measday, V.; Van Vuuren, H.J.J. Functional improvement of *Saccharomyces cerevisiae* to reduce volatile acidity in wine. *FEMS Yeast Res.* **2013**, *13*, 485–494. [[CrossRef](#)] [[PubMed](#)]
34. Casal, M.; Paiva, S.; Queirós, O.; Soares-Silva, I. Transport of carboxylic acids in yeasts. *FEMS Microbiol. Rev.* **2008**, *32*, 974–994. [[CrossRef](#)] [[PubMed](#)]
35. Salmon, J.M. L-Malic acid permeation in resting cells of anaerobically grown *Saccharomyces cerevisiae*. *Biochim. Biophys. Acta* **1987**, *901*, 30–34. [[CrossRef](#)]
36. Benito, Á.; Jeffares, D.; Palomero, F.; Calderón, F.; Bai, F.-Y.; Bähler, J.; Benito, S. Selected *Schizosaccharomyces pombe* strains have characteristics that are beneficial for winemaking. *PLoS ONE* **2016**, *11*, e0151102. [[CrossRef](#)] [[PubMed](#)]
37. Rodriguez, S.B.; Thornton, R.J. A malic acid dependent mutant of *Schizosaccharomyces malidevorans*. *Arch. Microbiol.* **1989**, *152*, 564–566. [[CrossRef](#)]
38. Gao, C.; Fleet, G.H. Degradation of malic and tartaric acids by high density cell suspensions of wine yeasts. *Food Microbiol.* **1995**, *12*, 65–71. [[CrossRef](#)]
39. Côte-Real, M.; Leão, C.; Van Uden, N. Transport of L(–)malic acid and other dicarboxylic acids in the yeast *Candida sphaerica*. *Appl. Microbiol. Biotechnol.* **1989**, *31*, 551–555. [[CrossRef](#)]
40. Côte-Real, M.; Leão, C. Transport of malic acid and other dicarboxylic acids in the yeast *Hansenula anomala*. *Appl. Environ. Microbiol.* **1990**, *56*, 1109–1113. [[PubMed](#)]
41. Queirós, O.; Casal, M.; Althoff, S.; Moradas-Ferreira, P.; Leão, C. Isolation and characterization of *Kluyveromyces marxianus* mutants deficient in malate transport. *Yeast* **1998**, *14*, 401–407. [[CrossRef](#)]
42. Zmijewski, M.J.; Macquillan, A.M. Dual effects of glucose on dicarboxylic acid transport in *Kluyveromyces lactis*. *Can. J. Microbiol.* **1975**, *21*, 473–480. [[CrossRef](#)] [[PubMed](#)]
43. Baranowski, K.; Radler, F. The glucose dependent transport of L-malate in *Zygosaccharomyces bailii*. *Antonie Van Leeuwenhoek* **1984**, *50*, 329–340. [[CrossRef](#)] [[PubMed](#)]
44. Pretorius, I.S.; Bauer, F.F. Meeting the consumer challenge through genetically customized wine-yeast strains. *Trends Biotechnol.* **2002**, *20*, 426–432. [[CrossRef](#)]
45. Rodriguez, S.B.; Thornton, R.J. Factors influencing the utilization of L-malate by yeasts. *FEMS Microbiol. Lett.* **1990**, *60*, 17–22. [[CrossRef](#)] [[PubMed](#)]
46. Volschenk, H.; van Vuuren, H.J.J.; Viljoen-Bloom, M. Malo-ethanolic fermentation in *Saccharomyces* and *Schizosaccharomyces*. *Curr. Genet.* **2003**, *43*, 379–391. [[CrossRef](#)] [[PubMed](#)]
47. Osothsilp, C.; Subden, R.E. Isolation and characterization of *Schizosaccharomyces pombe* mutants with defective NAD-dependent malic enzyme. *Can. J. Microbiol.* **1986**, *32*, 481–486. [[CrossRef](#)]
48. Volschenk, H.; Viljoen, M.; Grobler, J.; Petzold, B.; Bauer, F.; Subden, R.E.; Young, R.A.; Lonvaud, A.; Denayrolles, M.; van Vuuren, H.J.J. Engineering pathways for malate degradation in *Saccharomyces cerevisiae*. *Nat. Biotechnol.* **1997**, *15*, 253–257. [[CrossRef](#)] [[PubMed](#)]
49. Lancar-Benba, J.; Foucher, B.; Saint-Macary, M. Characterization, purification and properties of the yeast mitochondrial dicarboxylate carrier (*Saccharomyces cerevisiae*). *Biochimie* **1996**, *78*, 195–200. [[CrossRef](#)]
50. Palmieri, L.; Palmieri, F.; Runswick, M.J.; Walker, J.E. Identification by bacterial expression and functional reconstitution of the yeast genomic sequence encoding the mitochondrial dicarboxylate carrier protein. *FEBS Lett.* **1996**, *399*, 299–302. [[CrossRef](#)]

51. Palmieri, F.; Agrimi, G.; Blanco, E.; Castegna, A.; Di Noia, M.-A.; Iacobazzi, V.; Lasorsa, F.-M.; Marobbio, C.M.T.; Palmieri, L.; Scarcia, P.; et al. Identification of mitochondrial carriers in *Saccharomyces cerevisiae* by transport assay of reconstituted recombinant proteins. *Biochim. Biophys. Acta* **2006**, *1757*, 1249–1262. [[CrossRef](#)] [[PubMed](#)]
52. Palmieri, L.; Vozza, A.; Honlinger, A.; Dietmeier, K.; Palmisano, A.; Zara, V.; Palmieri, F. The mitochondrial dicarboxylate carrier is essential for the growth of *Saccharomyces cerevisiae* on ethanol or acetate as the sole carbon source. *Mol. Microbiol.* **1999**, *31*, 569–577. [[CrossRef](#)] [[PubMed](#)]
53. Cavero, S.; Vozza, A.; del Arco, A.; Palmieri, L.; Villa, A.; Blanco, E.; Runswick, M.J.; Walker, J.E.; Cerdan, S.; Palmieri, F.; et al. Identification and metabolic role of the mitochondrial aspartate-glutamate transporter in *Saccharomyces cerevisiae*. *Mol. Microbiol.* **2003**, *50*, 1257–1269. [[CrossRef](#)] [[PubMed](#)]
54. Ribéreau-Gayon, P.; Glories, Y.; Maujean, A.; Dubourdieu, D. Alcohols and other volatile compounds. The chemistry of wine stabilization and treatments. In *Handbook of Enology*, 2nd ed.; John Wiley & Sons Ltd.: Chichester, UK, 2006; Volume 2, pp. 51–64. [[CrossRef](#)]
55. Office Internationale de la Vigne et du Vin. *International Code of Oenological Practices*; OIV: Paris, France, 2010.
56. Vilela-Moura, A.; Schuller, D.; Falco, V.; Mendes-Faia, A.; Côte-Real, M. Effect of refermentation conditions and micro-oxygenation on the reduction of volatile acidity by commercial *S. cerevisiae* strains and their impact on the aromatic profile of wines. *Int. J. Food Microbiol.* **2010**, *141*, 165–172. [[CrossRef](#)] [[PubMed](#)]
57. Vasserot, Y.; Mornet, F.; Jeandet, P. Acetic acid removal by *Saccharomyces cerevisiae* during fermentation in oenological conditions. Metabolic consequences. *Food Chem.* **2010**, *119*, 1220–1223. [[CrossRef](#)]
58. Schüller, H.J. Transcriptional control of nonfermentative metabolism in the yeast *Saccharomyces cerevisiae*. *Curr. Genet.* **2003**, *43*, 139–160. [[CrossRef](#)] [[PubMed](#)]
59. Dos Santos, M.M.; Gombert, A.K.; Christensen, B.; Olsson, L.; Nielsen, J. Identification of in vivo enzyme activities in the cometabolism of glucose and acetate by *Saccharomyces cerevisiae* by using ¹³C-labeled substrates. *Eukaryot. Cell* **2003**, *2*, 599–608. [[CrossRef](#)] [[PubMed](#)]
60. Casal, M.; Cardoso, H.; Leão, C. Mechanisms regulating the transport of acetic acid in *Saccharomyces cerevisiae*. *Microbiology* **1996**, *142*, 1385–1390. [[CrossRef](#)] [[PubMed](#)]
61. Casal, M.; Cardoso, H.; Leão, C. Effects of ethanol and other alkanols on transport of acetic acid in *Saccharomyces cerevisiae*. *Appl. Environ. Microbiol.* **1998**, *64*, 665–668. [[PubMed](#)]
62. Casal, M.; Paiva, S.; Andrade, R.P.; Gancedo, C.; Leão, C. The lactate-proton symport of *Saccharomyces cerevisiae* is encoded by JEN1. *J. Bacteriol.* **1999**, *181*, 2620–2623. [[PubMed](#)]
63. Paiva, S.; Devaux, F.; Barbosa, S.; Jacq, C.; Casal, M. Ady2p is essential for the acetate permease activity in the yeast *Saccharomyces cerevisiae*. *Yeast* **2004**, *21*, 201–210. [[CrossRef](#)] [[PubMed](#)]
64. Vilela-Moura, A. Isolation and Characterization of Yeasts: Application in Controlled Processes of Volatile Acidity Bio-Reduction in Wines. Ph.D. Thesis, University os Trás-os-Montes e Alto Douro (UTAD), Vila Real, Portugal, 2010.
65. Vilela, A.; Amaral, C.; Shuller, D.; Mendes-Faia, A.; Corte-Real, M. Combined use of Wallerstein and *Zygosaccharomyces bailii* modified differential media to isolate yeasts for the controlled reduction of volatile acidity of grape musts and wines. *J. Biotech. Res.* **2015**, *6*, 43–53.
66. Pizarro, F.; Vargas, F.A.; Agosin, E. A systems biology perspective of wine fermentations. *Yeast* **2007**, *24*, 977–991. [[CrossRef](#)] [[PubMed](#)]
67. Martínez-Moreno, R.; Morales, P.; Gonzalez, R.; Mas, A.; Beltran, G. Biomass production and alcoholic fermentation performance of *Saccharomyces cerevisiae* as a function of nitrogen source. *FEMS Yeast Res.* **2012**, *12*, 477–485. [[CrossRef](#)] [[PubMed](#)]
68. Eglinton, J.M.; Henschke, P.A. Restarting incomplete fermentations: The effect of high concentrations of acetic acid. *Aust. J. Grape Wine Res.* **1999**, *52*, 71–78. [[CrossRef](#)]
69. Lilly, M.; Lambrechts, M.G.; Pretorius, I.S. Effect of increased yeast alcohol acetyltransferase activity on flavor profiles of wine and distillates. *Appl. Environ. Microbiol.* **2000**, *66*, 744–753. [[CrossRef](#)] [[PubMed](#)]
70. Carlton, W.K.; Gump, B.; Fugelsang, K.; Hasson, A.S. Monitoring acetaldehyde concentrations during MO of red wine by headspace solid-phase micro extraction with on-fiber derivatization. *J. Agric. Food Chem.* **2007**, *55*, 5620–5625. [[CrossRef](#)] [[PubMed](#)]

71. Genisheva, Z.; Teixeira, J.A.; Oliveira, J.M. Immobilized cell systems for batch and continuous winemaking. *Trends Food Sci. Technol.* **2014**, *40*, 33–47. [[CrossRef](#)]
72. Vilela, A.; Schuller, D.; Mendes-Faia, A.; Côrte-Real, M. Reduction of volatile acidity of acidic wines by immobilized *Saccharomyces cerevisiae* cells. *Appl. Microbiol. Biotechnol.* **2013**, *97*, 4991–5000. [[CrossRef](#)] [[PubMed](#)]



© 2017 by the author. Licensee MDPI, Basel, Switzerland. This article is an open access article distributed under the terms and conditions of the Creative Commons Attribution (CC BY) license (<http://creativecommons.org/licenses/by/4.0/>).